

# Drive User Guide

With EtherCAT (CoE) Interface



**D1-N**



**D2**



**D1**

**HIWIN**<sup>®</sup>  
Motion Control and System Technology

## Contexts

1.	Communication Specification of EtherCAT .....	4
2.	Physical Dimensions.....	5
3.	Object Dictionary Table.....	8
3.1	Data Type .....	8
3.2	Common Objects .....	8
3.3	PDO Mapping Objects.....	9
3.4	Communication Objects of Sync Manager .....	9
3.5	CiA 402 Objects of Guide Regulations .....	10
3.6	Manufacturer Defined Objects .....	12
3.7	Objects description of the Manufacture Defined Objects.....	12
4.	Communication Architecture of EtherCAT Drive .....	15
5.	State Machine of EtherCAT .....	17
6.	State Machine of CiA402 .....	19
7.	PDO Mapping.....	21
8.	Synchronization Mode .....	23
9.	Drive’s Mode of Operation .....	24
9.1	Position Control Mode.....	24
9.1.1	Profile Position Mode (PP).....	24
9.1.2	Cyclic Synchronization Position Mode .....	28
9.2	Velocity Control Mode .....	30
9.3	Torque Control Mode.....	32
9.4	Homing Mode .....	33
10.	Touch Probe Function .....	41
A.	How to use TwinCAT making connection with drive .....	43
B.	How to use TwinCAT operating drive in position mode .....	46
C.	How to use TwinCAT to process dynamic PDO Mapping.....	52
D.	How to setup the Operational Mode for EtherCAT .....	53

Drive User Guide  
Revision History

Release	Date	Applies to	Notice
1.0		D-series CoE Drive	First Release

# 1. Communication Specification of EtherCAT

<b>EtherCAT Communication</b>	Communication Standards	IEC 61158 Type 12 IEC 61800-7 CiA402 Drive Profile
	Physical Layer	100BASE-TX (IEEE802.3)
	SyncManager	SM0 – Mailbox output (Master → Slave) SM1 – Mailbox input (Slave → Master) SM2 – Process data outputs SM3 – Process data inputs
	Process Data	Dynamic PDO mapping
	Mailbox (CoE)	SDO Request
	Synchronization	Free run DC mode (DC cycle: 250us, 500us, 1ms, 2ms, 4ms)
	<b>CiA402 Drive Profile</b>	Homing mode
Profile position mode		
Profile velocity mode		
Profile torque mode		
Cyclic synchronization position mode		
Cyclic synchronization velocity mode		
Cyclic synchronization torque mode		
Touch probe function		

## 2. Physical Dimensions

### D1NCOE drive

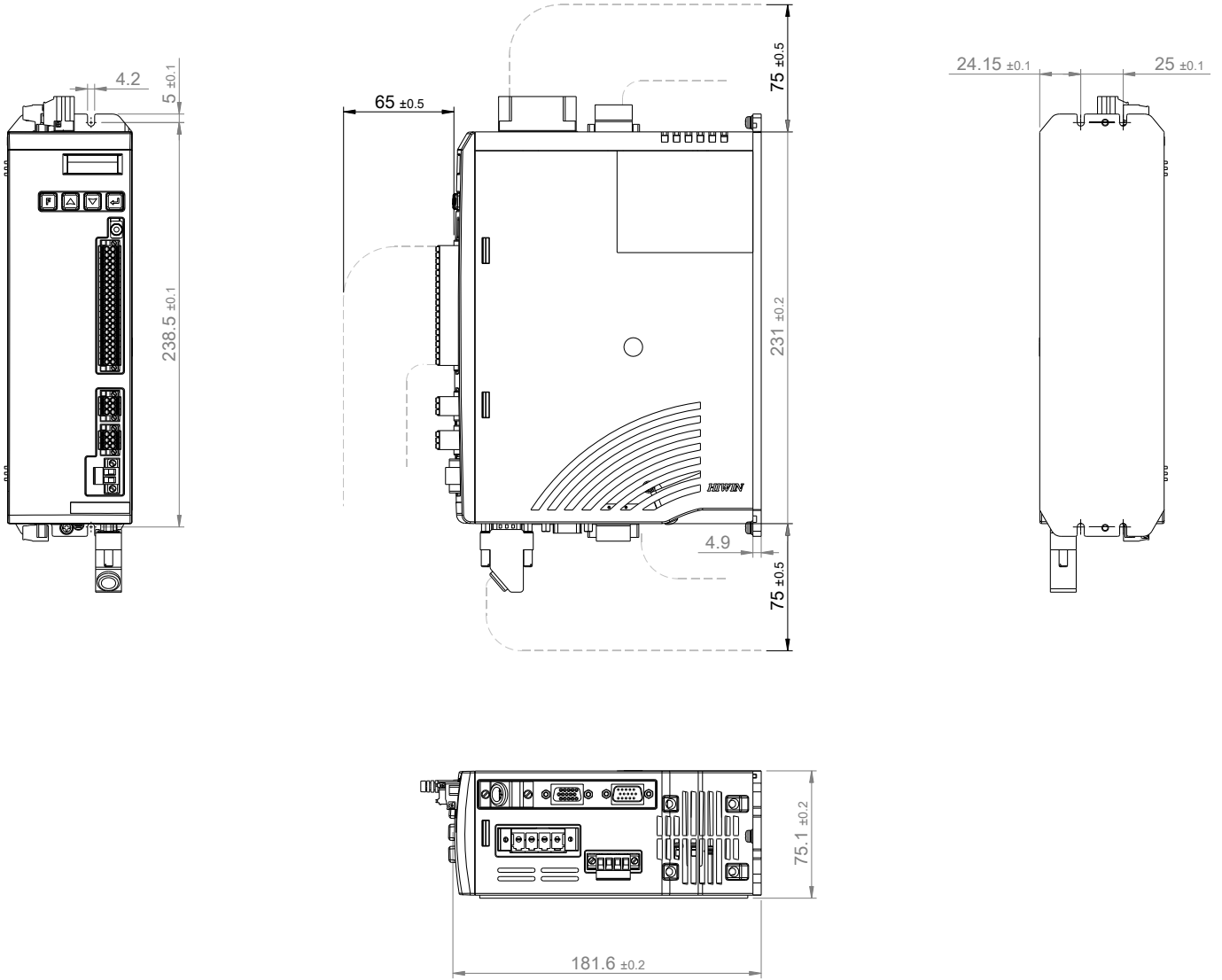

# D1COE drive

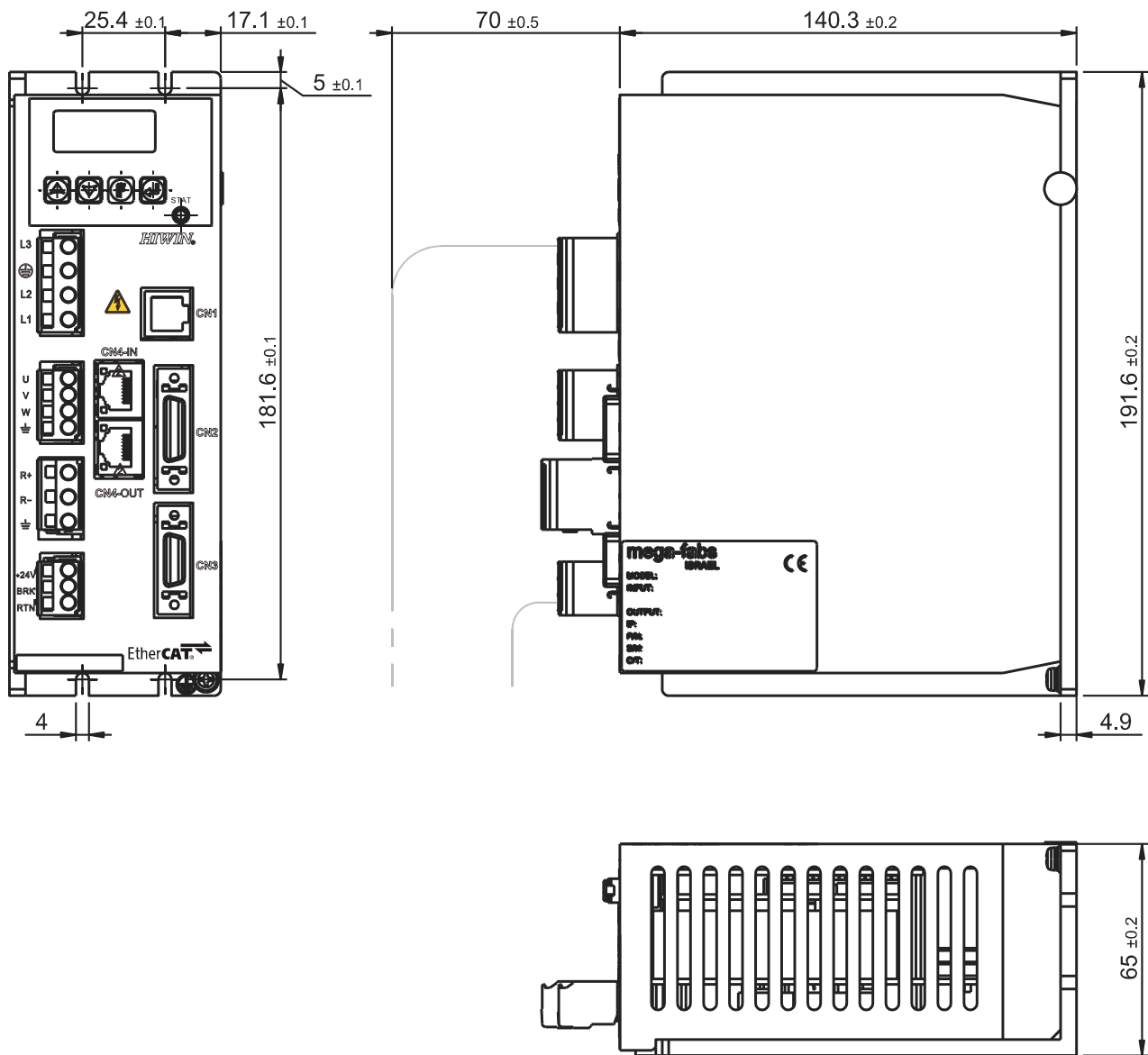

# D2COE drive

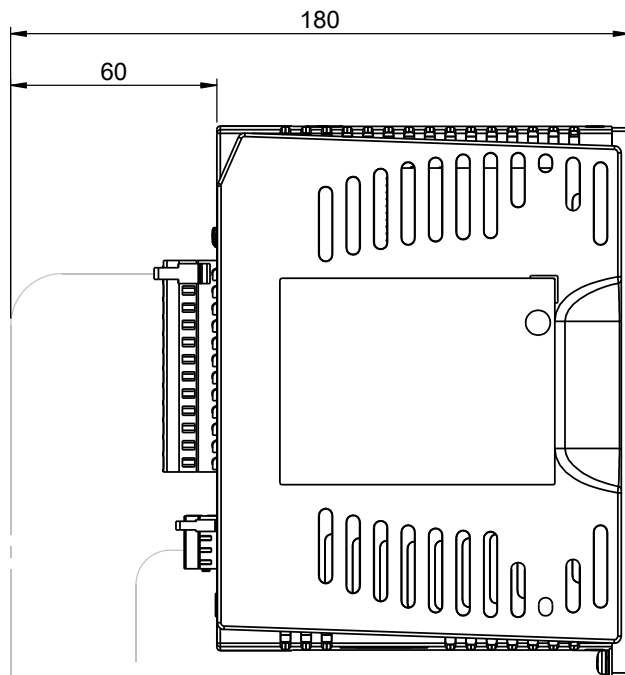
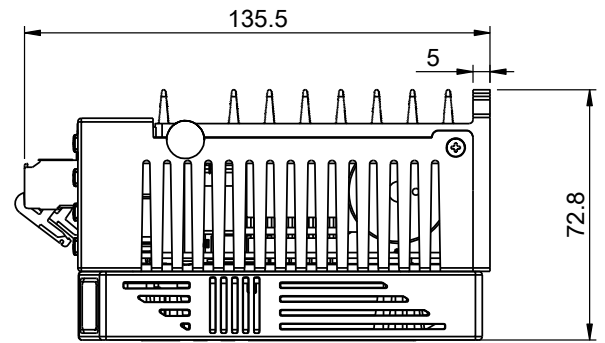
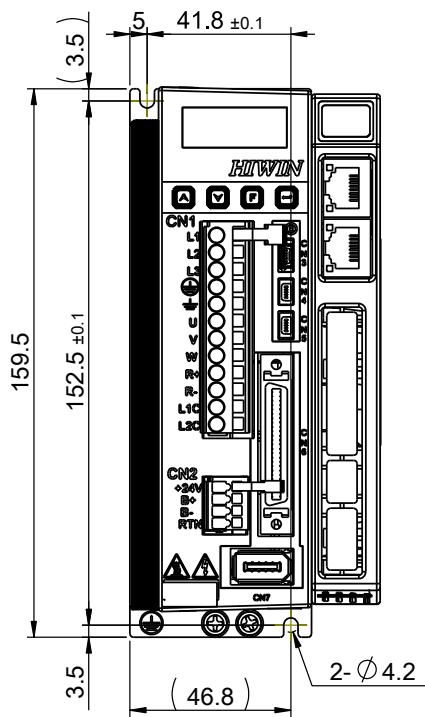

### 3. Object Dictionary Table

This table lists the data types and range used in this manual and drive.

#### 3.1 Data Type

Code	Data Type	Range
INT8	Signed 8 bit	-128 to +127
INT16	Signed 16 bit	-32768 to +32767
INT32	Signed 32 bit	-2147483648 to +2147483647
UINT8	Unsigned 8 bit	0 to 255
UINT16	Unsigned 16 bit	0 to 65535
UINT32	Unsigned 32 bit	0 to 4294967295
REAL32	Float 32 bit	---

The list below is the object dictionary table supporting by D2EtherCAT Drive.

#### 3.2 Common Objects

○ : Support, X : Not Support

Index	Sub-index	Name	Type	Access	Value	PDO mapping
0x1000	0x00	Device type	UINT32	RO	0x00020192	X
0x1001	0x00	Error register	UINT8	RO	—	X
0x1018	Identity Object					
	0x00	Number of entries	UINT8	RO	0x4	X
	0x01	Vendor ID	UINT32	RO	0x0000AAAA	X
	0x02	D1NCOE Product code	UINT32	RO	0x00000001	X
		D1COE Product code	UINT32	RO	0x00000002	X
		D2COE Product code	UINT32	RO	0x00000003	X
	0x03	Revision number	UINT32	RO	0x00000000	X
0x04	Serial number	UINT32	RO	0x00000000	X	



### 3.3 PDO Mapping Objects

○ : Support, X : Not Support

Index	Sub-index	Name	Type	Access	Value	PDO mapping
0x1600	Receive PDO Mapping					
	0x00	Number of objects	UINT8	RW	0x06	X
	0x01	Mapping entry1	UINT32	RW	0x60400010	X
	0x02	Mapping entry2	UINT32	RW	0x607A0020	X
	0x03	Mapping entry3	UINT32	RW	-----	X
	0x04	Mapping entry4	UINT32	RW	-----	X
	0x05	Mapping entry5	UINT32	RW	-----	X
	0x06	Mapping entry6	UINT32	RW	-----	X
0x1A00	Transmit PDO Mapping					
	0x00	Number of objects	UINT8	RW	0x06	X
	0x01	Mapping entry1	UINT32	RW	0x60410010	X
	0x02	Mapping entry2	UINT32	RW	0x60640020	X
	0x03	Mapping entry3	UINT32	RW	0x606C0020	X
	0x04	Mapping entry4	UINT32	RW	-----	X
	0x05	Mapping entry5	UINT32	RW	-----	X
	0x06	Mapping entry6	UINT32	RW	-----	X

### 3.4 Communication Objects of Sync Manager

○ : Support, X : Not Support

Index	Sub-index	Name	Type	Access	Value	PDO mapping
0x1C00	SYNC Manager Communication Type					
	0x00	Number of used sync manager	UINT8	RO	0x04	X
	0x01	Sync manager0	UINT8	RO	0x01	X
	0x02	Sync manager1	UINT8	RO	0x02	X
	0x03	Sync manager2	UINT8	RO	0x03	X
	0x04	Sync manager3	UINT8	RO	0x04	X

## Drive User Guide

0x1C12	SYNC Manager PDO Assignment 2					
	0x00	Number of assigned RxPDOs	UINT8	RW	0x01	X
	0x01	Assigned RxPDO mapping object1	UINT16	RW	0x1600	X
0x1C13	SYNC Manager PDO Assignment 3					
	0x00	Number of assigned TxPDOs	UINT8	RW	0x01	X
	0x01	Assigned TxPDO mapping object1	UINT16	RW	0x1A00	X

## 3.5 CiA 402 Objects of Guide Regulations

O : Support, X : Not Support

Index	Sub-index	Name	Type	Access	Value	PDO mapping
0x6040	0x00	ControlWord	UINT16	RW	—	O
0x6041	0x00	StatusWord	UINT16	RO	—	O
0x6060	0x00	Mode of operation	INT8	RW	—	O
0x6061	0x00	Mode of operation display	INT8	RO	—	O
0x6063	0x00	Position Actual Internal Value	INT32	RO	—	O
0x6064	0x00	Position Actual Value	INT32	RO	—	O
0x6065	0x00	Following Error Window	UINT32	RW	—	X
0x606C	0x00	Velocity Actual Value	INT32	RO	—	O
0x6071	0x00	Target Torque	INT16	RW	-1000~1000	O
0x6075	0x00	Continuous Current of Motor (mA)	UINT32	RW	—	X
0x6078	0x00	Current Feedback of Motor (0.1%)	INT16	RO	—	O
0x607A	0x00	Target Position	INT32	RW	—	O
0x607C	0x00	Home offset	INT32	RW	—	X
0x607D	Software Position Limit					
	0x00	Number of entries	UINT8	RO	0x2	X
	0x01	Minimum Position Limit	INT32	RW	—	X
	0x02	Maximum Position Limit	INT32	RW	—	X
0x607F	0x00	Maximum Profile Velocity	UINT32	RW	—	X

## Drive User Guide

Index	Sub-index	Name	Type	Access	Value	PDO mapping
0x6081	0x00	Profile Velocity	UINT32	RW	—	X
0x6083	0x00	Profile Acceleration	UINT32	RW	—	X
0x6084	0x00	Profile Deceleration	UINT32	RW	—	X
0x6085	0x00	Quick Stop Deceleration	UINT32	RW	—	O
0x6087	0x00	Torque Slope	UINT32	RW	—	O
0x6098	0x00	Homing Method	UINT16	RW	—	X
0x6099	Homing Speeds					
	0x00	Number of entries	UINT8	RD	0x02	X
	0x01	Speed during search for switch	UINT32	RW	—	X
	0x02	Speed during search for zero	UINT32	RW	—	X
0x609A	0x00	Homing Acceleration	UINT32	RW	1000000	X
0x60B1	0x00	Velocity Offset	INT32	RW	-1000~1000	O
0x60B2	0x00	Torque Offset	INT16	RW	-1000~1000	O
0x60B8	0x00	Touch Probe Function	UINT16	RW	—	O
0x60B9	0x00	Touch Probe Status	INT32	RO	—	O
0x60BA	0x00	Touch Probe 1 Position Value	INT32	RO	—	O
0x60C2	Interpolation Time Period					
	0x00	Highest sub-index supported	INT8	RO	1	X
	0x01	Interpolation time period	UINT16	RW	8	X
0x60F4	0x00	Following Error Actual Value	INT32	RD	—	O
0x60FC	0x00	Position Demand Internal Value	INT32	RO	—	O
0x60FD	0x00	Digital Inputs	UINT32	RO	—	O
0x60FF	0x00	Target Velocity	UINT32	RW	—	O
0x6502	0x00	Supported Drive Mode	UINT32	RO	0x3AF	X

### 3.6 Manufacturer Defined Objects

O : Support, X : Not Support

Index	Sub-index	Name	Type	Access	Default Value	PDO mapping
0x2000	0x00	Motor type	UINT16	RO	—	X
0x2001	0x00	Encoder Resolution of Velocity Loop	INT32	RO	—	X
0x2002	0x00	Encoder Resolution of Position Loop	INT32	RO	—	X
0x2003	0x00	Screw Pitch	INT32	RO	—	X
0x2010	0x00	Input Function	UINT16	RW	0x0	O
0x2020	0x00	Index Signal	INT8	RO	—	X
0x2021	0x00	Latched Index Position	INT32	RO	—	O
0x2022	0x00	Motor actual current	REAL32	RO	—	O
0x2040	0x00	Use the 2 <sup>nd</sup> linear digital encoder	UINT16	RO	—	X
0x2041	0x00	Enable software position limit protection	UINT16	RW	0x01	X
0x2042	0x00	Enable hardware limit protection	UINT16	RW	0x01	X
0x2050	0x00	Common gain (CG:0.01~1.0)	REAL32	RW	0.3	X
0x2051	0x00	Velocity proportional gain	REAL32	RW	0.001	X
0x2060	0x00	Multi turn encoder reset flag	UINT8	RW	0	X
0x2100	0x00	Drive Error Events 1	UINT32	RO	0	X
0x2101	0x00	Drive Error Events 2	UINT32	RO	0	X

### 3.7 Objects description of the Manufacture Defined Objects

**0x2000 - Motor type**

- 0: Linear motor
- 1: Torque motor
- 2: AC servo motor

**0x2001 - Encoder resolution of velocity loop**

The encoder resolution is the rotary encoder resolution.

**0x2002 - Encoder resolution of position loop**

The encoder resolution is the linear scale resolution. (The AC servo motor with ball screw)

**0x2003 - Screw pitch**

The value is corresponded to the ball screw user using.

## Drive User Guide

### **0x2010 - Input function**

bit0 - Activate error mapping

bit1 - Reset the drive.

### **0x2020 – Index signal**

The object is used to home procedures by host controller.

0: No Index.

1: Index is touched.

### **0x2021 – Latch Index position**

This object is for user checking the repeatability of home position.

### **0x2022 – Motor actual current**

This object is used to display Ampere unit of the current value.

### **0x2040 – Use the 2<sup>nd</sup> linear digital encoder**

0: Not use the 2<sup>nd</sup> linear digital encoder

1: Use the 2<sup>nd</sup> linear digital encoder

### **0x2041 – Enable software position limit protection**

0: Disable the software position limit protection

1: Enable the software position limit protection

### **0x2042 – Enable hardware position limit protection**

0: Disable the hardware position limit protection

1: Enable the hardware position limit protection

### **0x2050 – Common gain**

This object is for user to tune the motor performance (stiffness) in all servo loop.

### **0x2051 – Velocity proportional gain**

This object is for user to tune the motor performance (stiffness) in velocity loop .

### **0x2051 – Velocity proportional gain**

This object is for user to tune the motor performance (stiffness) in velocity loop .

### **0x2060 – Multi turn encoder reset flag**

This object is used only for the multi turn encoder.

0: Nothing happen.

0->1: Set the multi turn encoder position to zero.

0->2: Clear the multi turn encoder error.

### **0x2100 – Drive Error Events 1**

Bit 1: Encoder error

Bit 6: Position error too big

Bit 7: Soft-thermal threshold reached

Bit 13: Serial encoder communication error

Bit 14: Motor over temperature sensor activated

Bit 15: Amplifier over temperature

Bit 18: Motor short (over current) detected

## Drive User Guide

Bit 19: Over voltage detected

Bit 20: Under voltage detected

Bit 21: Motor maybe disconnected

Bit 18: Motor short (over current) detected

Bit 31: 5V for encoder card fail

Others: reserved.

### **0x2101– Drive Error Events 2**

Bit 1: Phase initialization error

Bit 5: Hall sensor error

Bit 6: Hall phase check error

Others: reserved

## 4. Communication Architecture of EtherCAT Drive

The figure shown below indicates the architecture of CoE(CANopen over EtherCAT) drive network module. It can be separated to data link layer and application layer. Data link layer is used to manage the transmission interface of data between the master and salve station. Application layer is used to implement the function of state transition compatible between CiA402 (CANopen Drive Communication Protocol) and EtherCAT.

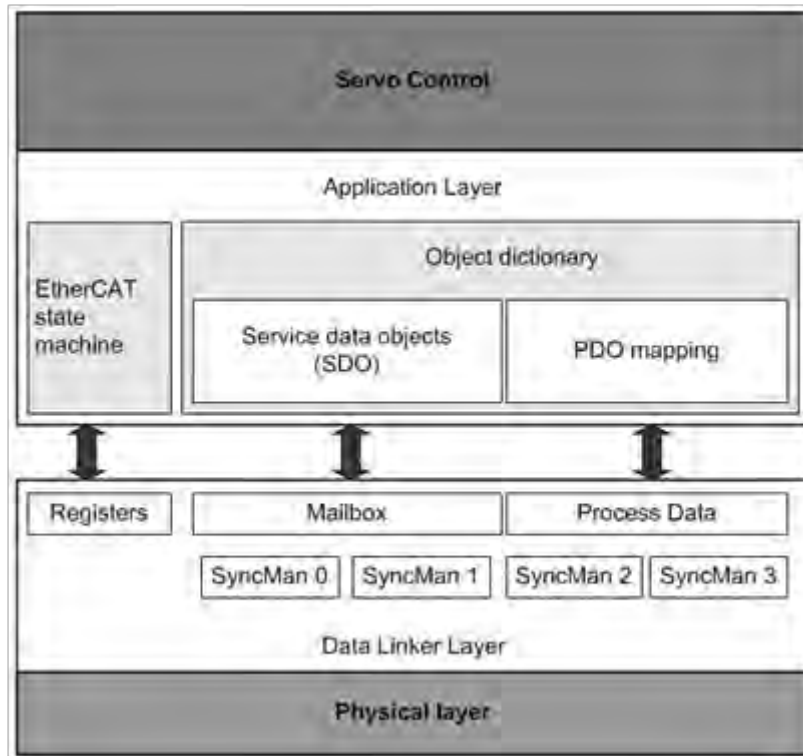

There are two types of data transition mode between the application layer and data link layer: time critical and non-time-critical data transition. Data of time critical indicates that the data transition has to complete within a specific time. If not, it may cause the control failure. The data of time critical is normally used in the periodic communication. It is called as cyclic process data communication. However, the data of non-time-critical is able to complete by using the non-periodic communication i.e. use non-periodic mailbox communication.

The process data object (PDO) in the application layer are consisted of the objects which can be mapping to PDO and the contents of process data defined in the PDO mapping; and process the read and write data through the periodic process data communication. However, the service data object (SDO) is to read and write the data in the object dictionary through the mailbox data communication.

The chart shown below indicates the layout between the process data of data link layer and the SyncManager of mailbox data communication:

## Drive User Guide

<b>Sync Manager</b>	<b>Purpose</b>	<b>Starting Address</b>
Sync Manager 0	Mailbox data communication - receive Mailbox	0x1800
Sync Manager 1	Mailbox data communication - transmit Mailbox	0x18F6
Sync Manager 2	Process data communication - receive PDO (RxPDO)	0x1000
Sync Manager 3	Process data communication - transmit PDO (TxPDO)	0x1100

The drive supporting EtherCAT shall provide the files used by the master station to plan the layout and communication between the master and slave stations. It is called ESI (EtherCAT Slave Information) and the format is xml files. The following three different files are the ESI of HIWIN CoE drive:

- D1N Drive - D1NCOE.xml
- D1 Drive - D1COE.xml
- D2 Drive - D2COE.xml



## 5. State Machine of EtherCAT

EtherCAT state machine (ESM) is used to coordinate the state of application layer from starting to normal operation between the master and slave stations. The switch of state normally is initiated by the master station. After receiving the command of switching state, the slave station starts to switch the state. As shown in the figure below, the transition of EtherCAT state machine. When the slave station starts to transit from the initialization state to the operational state, it must to follow the process of Initialization (Init) → Pre-Operational → Safe-Operational → Operational. Leapfrog transition is not allowed.

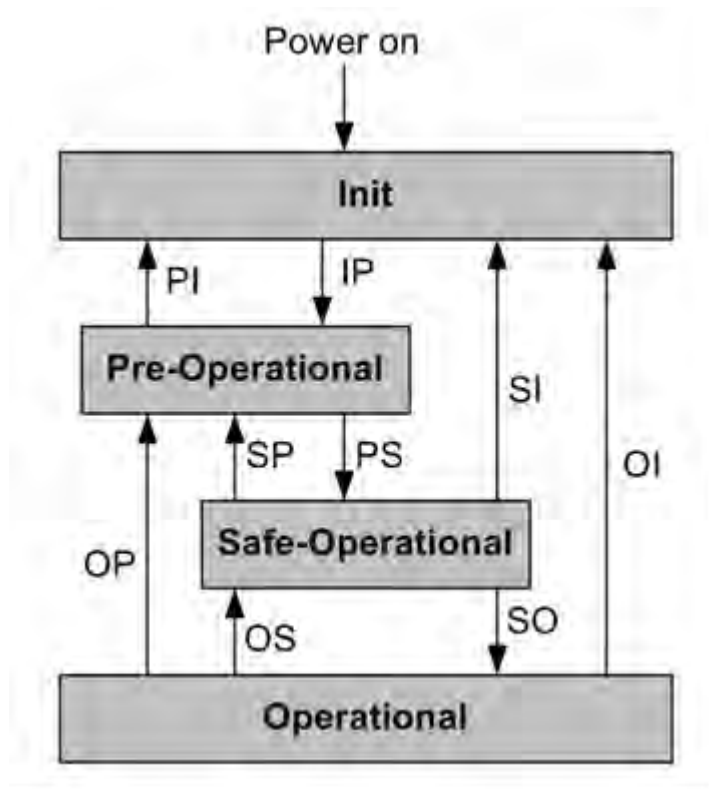

State	Description
Initialization (Init)	No mailbox communication. No process data communication.
Transit from Init to Pre-Operational, IP.	Master station set up the contents of relevant registers: <ul style="list-style-type: none"> <li>- Address register of DL.</li> <li>- SyncManager of relevant mailbox communication.</li> </ul> Distribute clock of master station initialization. Master station requests to enter Pre-Operational state. <ul style="list-style-type: none"> <li>- Set up AL Control register.</li> </ul>

## Drive User Guide

State	Description
	Wait for the response from AL Status register.
Pre-Operational	Able to use mailbox communication. No process data communication.
Transit from Pre-Operational to Safe-Operational, PS	Master station uses the mailbox communication to set up the contents of PDO Mapping. Master station set up the relevant SyncManager of process data communication. Master station requests to enter Safe-Operational state. <ul style="list-style-type: none"> <li>- Set up AL Control register.</li> </ul> Wait for the response from AL Status register.
Safe-Operational	Able to use mailbox communication. Able to use process data communication. <ul style="list-style-type: none"> <li>- Only able to use input type of process data communication.</li> </ul>
Transit from Safe-Operational to Operational, SO	Master station requests to enter Operational state. <ul style="list-style-type: none"> <li>- Set up AL Control register.</li> </ul> Wait for the response from AL Status register.
Operational	Able to use mailbox communication. Able to use both output and input types of process data communication.

## 6. State Machine of CiA402

Servo drive uses CANopen finite state machine (FSM) to define its state and the corresponding servo control function. Master station uses ControlWord object (0x6040) to control the switch of drive state and the drive uses StatusWord object (0x6041) to respond the current state of drive to the master station. The figure shown below is the state machine receiving order and switching state.

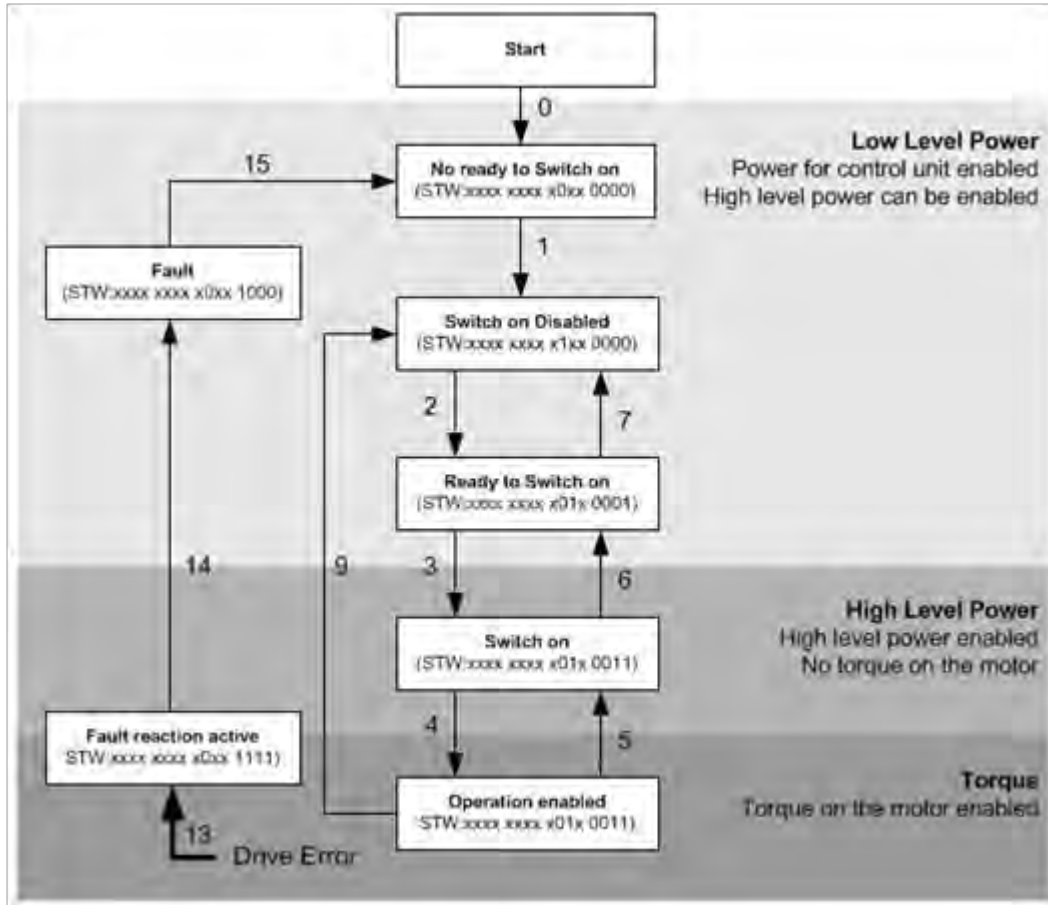

The chart below describes the various state machines:

State	Description
Not Ready to Switch On	Drive is in the state of not ready to read.
Switch On Disabled	Drive's main power switch is turned off and motor cannot be magnetized.
Ready to Switch On	Drive's main power switch is pending to turn on and motor cannot be magnetized.
Switch on	Drive's main power switch is turned on and motor can be magnetized through the set up of ControlWord.
Operation enabled	Motor has been magnetized and the drive can be operated normally.
Fault reaction active	Drive occurs error and activates corresponding motion.
Fault	Drive occurs error and has activated corresponding motion. Under

## Drive User Guide

	this state, the drive has de-magnetized the motor.
--	--

The chart below is the command of switching state using ControlWord (0x6040) by the master station:

Bit Command	Bit7	Bit3	Bit2	Bit1	Bit0	Transition Event
N/A	X	X	X	X	X	0
N/A	X	X	X	X	X	1
Shutdown	0	X	1	1	0	2, 6, 8
Switch On	0	0	1	1	1	3
Enable Operation	0	1	1	1	1	4
Disable Operation	0	0	1	1	1	5
Disable Voltage	0	X	X	0	X	7,9
Fault reset	0->1	X	X	X	X	X

The chart below showing the current state using StatusWord (0x6041) by the drive:

Bit State	Bit6	Bit5	Bit3	Bit2	Bit1	Bit0
Not Ready to Switch On	0	X	0	0	0	0
Switch On Disabled	1	X	0	0	0	0
Ready to Switch On	0	1	0	0	0	1
Switch On	0	1	0	0	1	1
Operation enabled	0	1	0	1	1	1
Fault	0	1	1	0	0	0
Fault reaction active	0	0	1	1	1	1

## 7. PDO Mapping

User is able to change the data transmitted through the process data communication between the master and slave stations based on the requirements. Receiving the process data communication is able to implement through set up the receiving objects separately from RxPDO mapping objects 0x1600 to 0x1602. Transmitting the process data communication is able to implement through set up the data objects to be transmitted from TxPDO mapping objects 0x1A00 to 0x1A03. The chart shown below is the data objects layout for the pre-set up process data communication. Take RxPDO mapping object 0x1600 as example to layout 3 ea data objects. The maximum numbers of data object allowed by the drive for the user to layout are 5 sets.

Mapping Objects	Data Objects				
RxPDO (0x1600)	ControlWord (0x6040)	Target Position (0x607A)	Mode of Operation (0x6060)	No Layout	No Layout
TxPDO (0x1A00)	StatusWord (0x6041)	Position Actual value (0x6064)	Velocity Actual value (0x606C)	No Layout	No Layout

If the user requires the dynamic configuration of process data communication, the drive shall be positioned as the Pre-Operational phase of EtherCAT state machine and process through the mailbox data communication. Processing steps are shown as follows:

### Shut off PDO layout of Sync Manager

Through set up the content of zero sub-index of communication object 0x1C12 and 0x1C13 to zero to complete. Use 0x1C12 object as the PDO layout for Sync Manager of RxPDO. 0x1C13 uses as the PDO layout for Sync Manager of TxPDO.

### Set up Required Data Objects

If the data objects are to be transmitted through RxPDO, it may designate the content of the first to the fifth sub-index of mapping objects 0x1600、0x1601 or 0x1602. Likewise, if it is TxPDO, then designate the data objects to the first to the fifth sub-index of 0x1A00、0x1A01 or 0x1A02.

### Set up Numbers of Layout Data Object of Specific Mapping Object

For example, RxPDO mapping object 0x1600 has been layout the dada object to be mapped from the first sub-index to the forth sub-index, then the zero sub-index of 0x1600 has to set up to 4.

**Allocate Mapping Object to PDO Layout Object of Sync Manage**

For example, allocate RxPDO mapping object 0x1600 to the content of the first sub-index of 0x1C1. Designate TxPDO mapping object 0x1A01 to 0x1C13.

**Set up Numbers of Mapping Object as Designated to PDO of Sync Manager**

Set up the zero sub-index of 0x1C12 and 0x1C13 to 1 to enable the transmission of PDO.

**Switch EtherCAT State Machine of Drive to Operational.**

## 8. Synchronization Mode

Drive provides two types of operational modes: Free-run mode and DC mode. Master station may select the operational mode through set up 0x098 of ESC register. For example:

- Free-run mode: Set up the register 0x0980 to 0x0000.
- DC mode: Set up the register 0x0980 to 0x0300.

DC mode is one of the synchronization mode which is completed through the mechanism of distribute clock. Drive uses the reference clock to generate the internal SYNC0 event to complete the synchronization function. The figure below is the schematic diagram of synchronization by using the DC reference clock. The cycle time can be supported by the drive are: 250us 、 500us 、 1ms 、 2ms 、 4ms.

Free-run mode goes through the register 0x0220 AL Events of ESC to complete the synchronization function. The flags generated by the data transmitting event of its Bit 10 and Bit 11, drive will detect the triggers of these two bits to transmit PDO data.

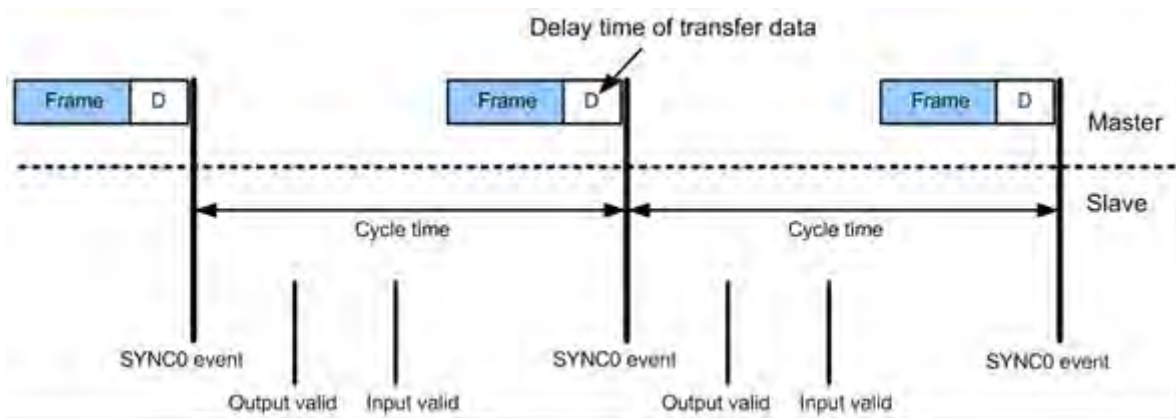

## 9. Drive’s Mode of Operation

Drive will operate based on the operational mode set up by the upper controller. Supportable modes are listed as follows:

- Profile Position mode
- Homing mode
- Profile Velocity mode
- Profile Torque mode
- Cyclic Synchronization Position mode
- Cyclic Synchronization Velocity mode
- Cyclic Synchronization Torque mode

The list below shown the objects relevant to the operational mode:

Index	Sub-index	Description	Type	Access	Value	PDO mapping
0x6060	0x00	Operational Mode	INT8	RW	—	<b>0</b>
0x6061	0x00	Current Operational Mode	INT8	RO	—	<b>0</b>
0x6502	0x00	Supportable Operational Mode	UINT32	RO	—	X

The operational mode may switch by changing the content of object 0x6060 and read the content of object 0x6061 to confirm the current operational mode of drive. The chart below shown the set up value of object 0x6060 and the mode represented:

Operational Mode	Set up Value of 0x6060
Profile Position mode	1
Profile Velocity mode	3
Profile Torque mode	4
Homing mode	6
Cyclic Synchronous Position mode	8
Cyclic Synchronous Velocity mode	9
Cyclic Synchronous Torque mode	10

### 9.1 Position Control Mode

#### 9.1.1 Profile Position Mode (PP)

Profile position mode is the planning velocity, acceleration, deceleration and target position transmitted by the master station to drive. Through the internal route planner generating the motion command and then through the position loop, velocity loop and current loop, finally output the current



## Drive User Guide

to drive the motor to complete the positioning purpose. The profile position mode is shown as the block diagram below.

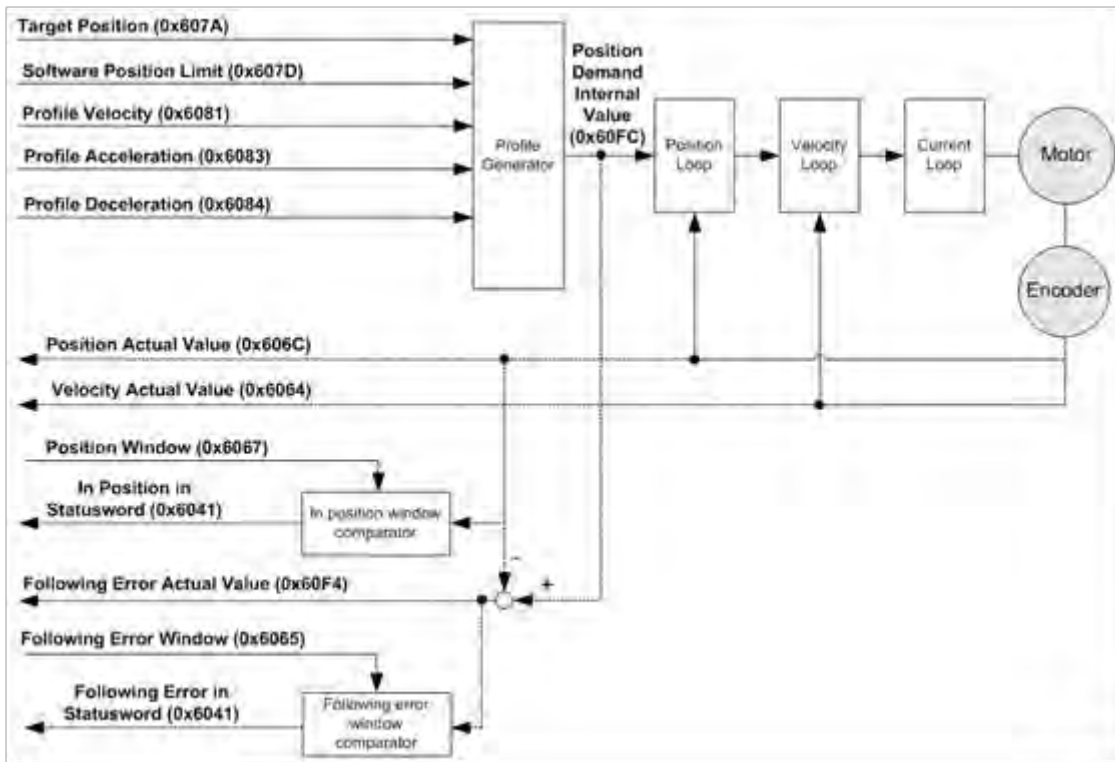

There are two motion modes under the profile position mode: Single set-point move mode and set of set-point move mode. Through set up ControlWord(0x6040), the master station initiates the movement of target position and read the content of StatusWord(0x6041) to know the movement status of motor. Describe separately as follows:

0x6040	Definition	Value	Description
Bit4	New Set Up Point	0	Not initiate the movement of next target position.
		1	Initiate the movement of next target position.
Bit5	Update Immediately	0	Movement of single target position.
		1	Movement of multiple target position.
Bit8	Halt	0	Not stop the movement of motor.
		1	Stop the movement of motor.

0x6041	Definition	Value	Description
Bit10	Motor in position	0	Motor has not been in-position in the target position.
		1	– Motor has been in-position to the target position.

## Drive User Guide

			- Complete the stop motion and the motor has been stopped.
Bit11	Internal limit active	0	Motor has not triggered the limit.
		1	Motor has triggered the limit (limit of hardware or software)
Bit12	Confirm new set up point	0	No new receiving target position available.
		1	New target position has been received and the motor starts to move.
Bit13	Following error	0	No following error.
		1	Following error exist.

### A. Single set-point mode:

After completing the motor moving to the previous target position, the controller of master station is able to initiate the movement of next target position. The operational sequence is shown as the figure below.

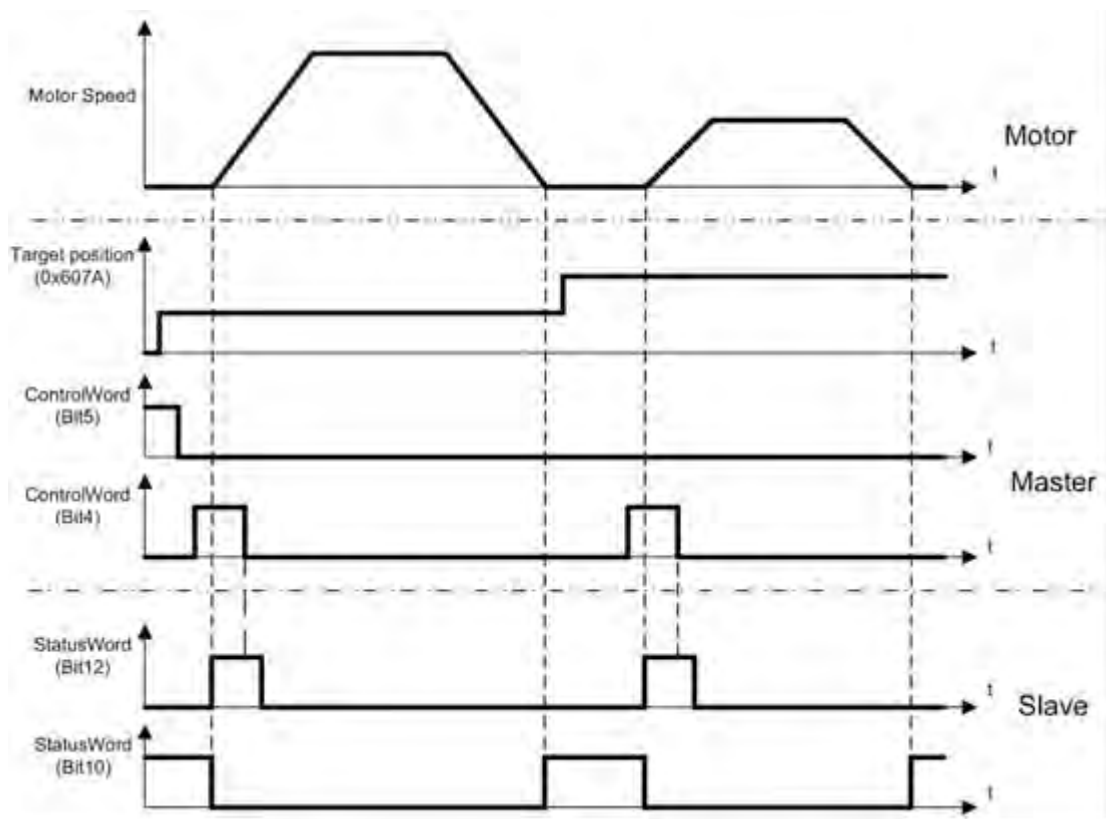

- (1) The controller of master station sets the bit5 of ControlWord(0x6060) to 0. Select the single set-point mode.
- (2) Master station sets the moving velocity (0x6081), unit is count/s.
- (3) Master station sets the acceleration velocity (0x6083) and deceleration (0x6084), unit is  $\text{count/s}^2$ .

## Drive User Guide

- (4) Master station sets the next target position (0x607A). It is an absolute coordinate and the unit is count.
- (5) Master station sets the bit4 of ControlWord(0x6040) to 1 and initiates the movement of target position.
- (6) Drive will set the bit12 of StatusWord(0x6041) to 1 and clear bit10 to 0. Inform master station that the new target position has been received and starts to move the motor.
- (7) When master station reads the bit12 of StatusWord(0x6041) being set to 1, clear the bit4 of ControlWord to 0.
- (8) After motor moving to the target position, drive sets the bit10 of StatusWord(0x6041) to 1. Inform the motor of master station that the positioning has been completed.
- (9) After master station confirming the positioning of motor, if the different velocity or acceleration/deceleration is required to move the motor to the new position, repeat step (2)~(7).

### B. Set of set-point moving mode:

During the process of moving the motor to the previous target position of set point, initiate the movement of next target position of new set point. The operational sequence is shown as the figure below.

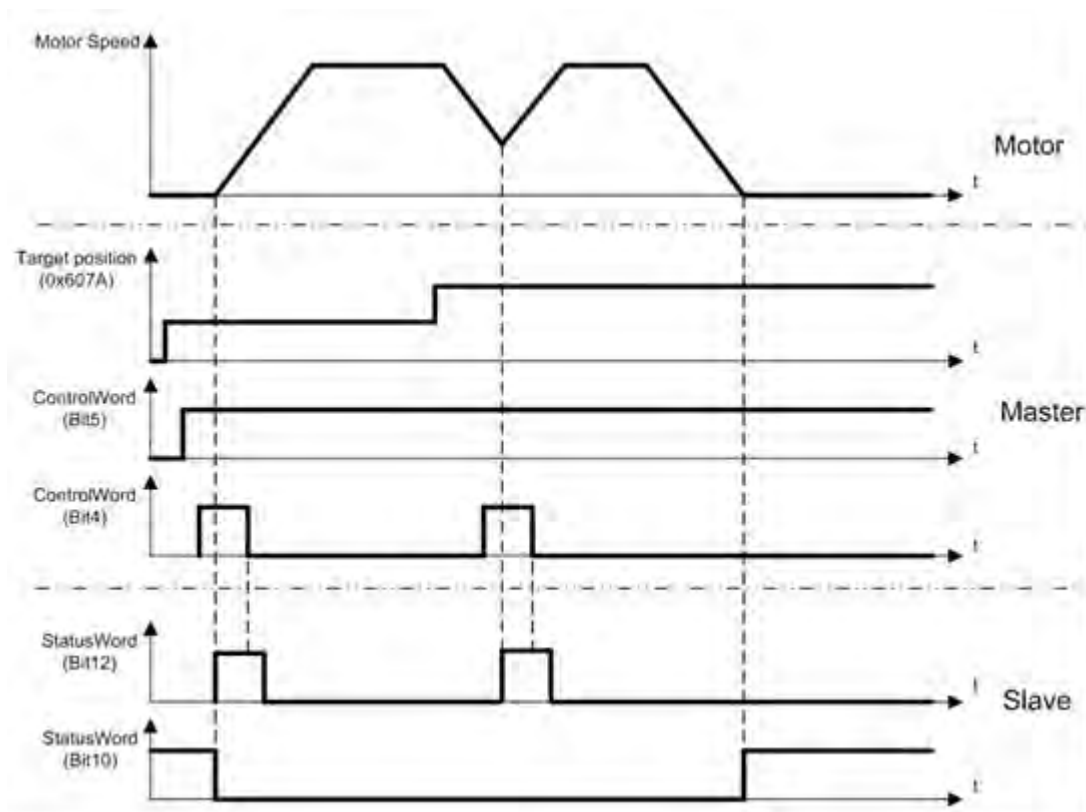

The controller of master station sets the bit5 of ControlWord(0x6040) to 1. Select set of set-point moving mode.

## Drive User Guide

Master station sets the moving velocity (0x6081), unit is count/s.

Master station sets the acceleration velocity (0x6083) and deceleration (0x6084), unit is  $\text{count/s}^2$ .

Master station sets the next target position (0x607A). It is an absolute coordinate and the unit is count.

Master station sets the bit4 of ControlWord(0x6040) to 1 and initiates the movement of target position.

Drive will set the bit12 of StatusWord(0x6041) to 1 and clear bit10 to 0. Inform master station that the new target position has been received and starts to move the motor.

When master station reads the bit12 of StatusWord(0x6041) being set to 1, it will clear the bit4 of ControlWord to 0.

During the movement of motor, master station may repeat step (4)~(6) to initiate the movement of new target position.

If the motor reaches the set position of software limit during the process of moving the motor to the target position or triggers the limit switch of hardware, the motor will stop to move immediately. The bit11 of StatusWord(0x6041) set by the drive will inform the controller of master station that the limit signal has been activated. If master station still continuously places the position command of the same direction, the bit12 of StatusWord(0x6041) set by the drive will inform the controller of master station that the new target position has been ignored. Therefore, the motor will not be moved. On the contrary, if master station places the position command of opposite direction, drive will receive this new command and move the motor to the target position. After the motor leaves away from the software limit or hardware limit switch, the bit11 of StatusWord(0x6041) will be cleared by the drive to 0.

### 9.1.2 Cyclic Synchronization Position Mode

Cyclic synchronization position mode is shown as the figure below. The controller of master station transmits the target position to the drive cyclically. The drive handles the control of position loop, velocity loop and current loop. Besides, interpolation time period 0x60C2 is used to define the update time period of target position. The drive uses the settings of interpolation time period to implement the interpolation of position. Under the control of synchronization mode (DC mode), the interpolation time period will automatically set up as the cycle time of SYNC0. If it is under the free run mode, the master station shall place the cycle time of position command ahead and set to the interpolation time period, then start to transmit the target position.

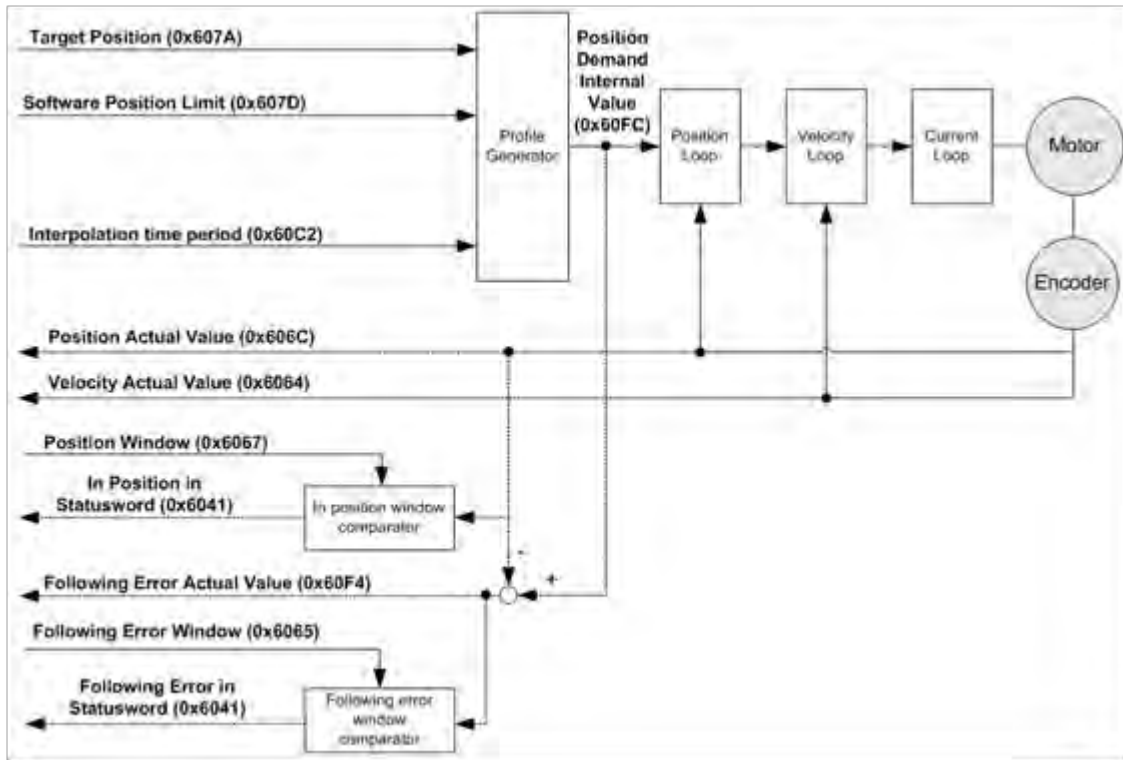

The following description describes the use of ControlWord(0x6040) and StatusWord(0x6041) by the controller of master station under the cyclic synchronization position mode:

0x6040	Definition	Value	Description
Bit8	Halt	0	Not stop the movement of motor.
		1	Stop the movement of motor.

0x6041	Definition	Value	Description
Bit10	Reach target position	0	Motor has not been positioned to the target position.
		1	<ul style="list-style-type: none"> <li>- Motor has been positioned to the target position.</li> <li>- Complete the stop motion and the motor has been stopped.</li> </ul>
Bit11	Internal Limit active	0	Limit is not triggered.
		1	Limit is triggered.
Bit12	Ignore target position	0	Ignore target position.
		1	Target position input to position control loop.
Bit13	Following error	0	No following error.
		1	Following error exist.

The steps of using the cyclic synchronization position mode to move the motor to the target position are listed as follows:

**I. Using cyclic synchronization position mode under Free-run mode:**

- (1) Confirm the target position (0x607A) has been mapping to RxPDO and actual position (0x606C) mapping to TxPDO. Please refer to Chapter 7, the setting method of PDO mapping.
- (2) Set up the content of interpolation period time (0x60C2:1) in accordance with the cycle time of update position command. For example, if the cycle of transmitting the target position command from the master station is 1ms, then the content of 0x60C2:1 shall be set to  $(1/0.0625)=16$ .
- (3) Set the content of operational mode (0x6060) to 8.
- (4) Confirm the content of operational mode (0x6061) has been set to 8. It indicates that the operational mode has been switched to the cyclic synchronization position mode.
- (5) Master station updates the new target position (0x607A) cyclically. The unit is count and position is absolute coordinate as well. Motor will move to the target position immediately.

**II. Using cyclic synchronization position mode under synchronization mode (DC mode):**

- (1) Confirm the target position (0x607A) has been mapping to RxPDO and the actual position (0x606C) has been mapping to TxPDO. Please refer to Chapter 7, the setting method of PDO mapping.
- (2) After switching on the distributed clock, the drive will automatically set up the content of interpolation time period (0x60C2:1) in accordance with the synchronization signal cycle as set up by the master station. For example, the synchronization signal cycle set up by the master station is 500us, then the drive will set up the interpolation time period to  $(0.5/0.0625=8)$ .
- (3) Set the content of operational mode (0x6060) to 8.
- (4) Confirm the content of operational mode (0x6061) has been set up to 8. It indicates that the operational mode has been switched to the cyclic synchronization position mode.
- (5) Master station updates the new target position (0x607A) cyclically. The unit is count and position is absolute coordinate as well. Motor will move to the target position immediately. °

When the software limit signal or the limit switch of hardware is triggered during the moving process, the bit11 of StatusWord(0x6041) will be set up to 1 and inform the motor of master station that the limit signal has been triggered and the bit12 of StatusWord(0x6041) will be cleared to 0. If master station still transmits the position command of the same direction, drive will ignore the new target position. Motor will stop at the position where the limit signal is triggered. Drive will re-designate the content of target position object (0x607A) to the current position of motor. If master station places the position command of opposite direction, drive will receive it and set up the bit12 of StatusWord(0x6041) to 1. Motor starts to move to the opposite direction. After the motor leaves away from the software limit or hardware limit switch, the bit11 of StatusWord(0x6041) will be cleared by the drive to 0.

## 9.2 Velocity Control Mode

The figure shown below is the control schematic diagram of profile velocity mode and cyclic synchronization velocity mode. Master station transmits the target velocity to the velocity control loop

## Drive User Guide

of drive. Under this control mode, the target velocity command will be limited by the protecting set up value of velocity and acceleration/deceleration.

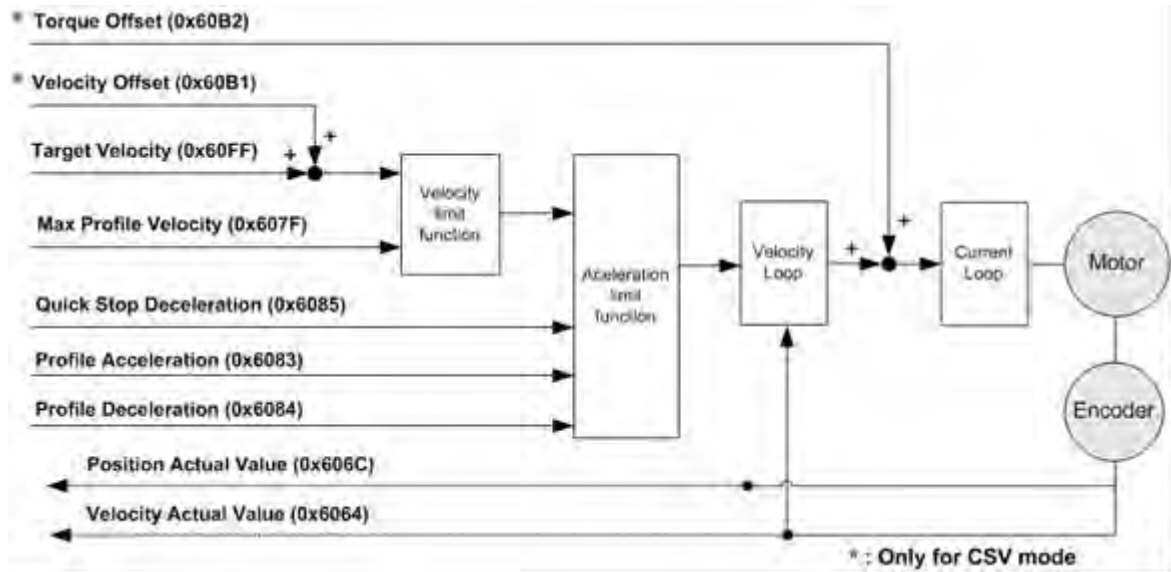

The following description describes the use of ControlWord(0x6040) and StatusWord(0x6041) by the controller of master station under the cyclic synchronization position mode:

0x6040	Definition	Value	Description
Bit8	Halt	0	Not stop the movement of motor.
		1	Stop the movement of motor.

0x6041	Definition	Value	Description
Bit11	Internal Limit active	0	Motor has not triggered the limit.
		1	Motor triggers the hardware limit signal.
Bit12	Ignore Target Velocity	0	Ignore target velocity.
		1	Target velocity enters into velocity control loop.

The steps of using profile velocity mode to operate the motor:

- (1) Confirm the target velocity command (0x60FF) has been mapping to RxPDO and the actual position (0x6064) object has been mapping into TxPDO. Please refer to Chapter 7, the setting method of PDO mapping.
- (2) A. If drive is to be operated under the profile velocity mode, the content of 0x6060 object shall be set to 3.  
B. If drive is to be operated under the cyclic synchronization velocity mode, the content of 0x6060 object shall be set to 9.
- (3) A. Confirm the content of 0x6061 object has been set to 3. It indicates that the operational

## Drive User Guide

mode has been switched to profile velocity mode.

B. Confirm the content of 0x6061 object has been set to 9. It indicates that the operational mode has been switched to the cyclic synchronization velocity mode.

- (4) Set up the maximum limit value of moving velocity (0x607F), the maximum limited value of acceleration/deceleration (0x6083、0x6084) and the deceleration value of emergency stop (0x6085). These units are count base.
- (5) Master station transmits target velocity (0x60FF). The unit is count/s. Motor will operate to the target velocity.

## 9.3 Torque Control Mode

The figure shown below is the control schematic diagram of profile torque mode (PT) and cyclic synchronization torque mode (CST). Operating under this mode, drive involves the current loop and accepts with the target current command transmitted from the master station.

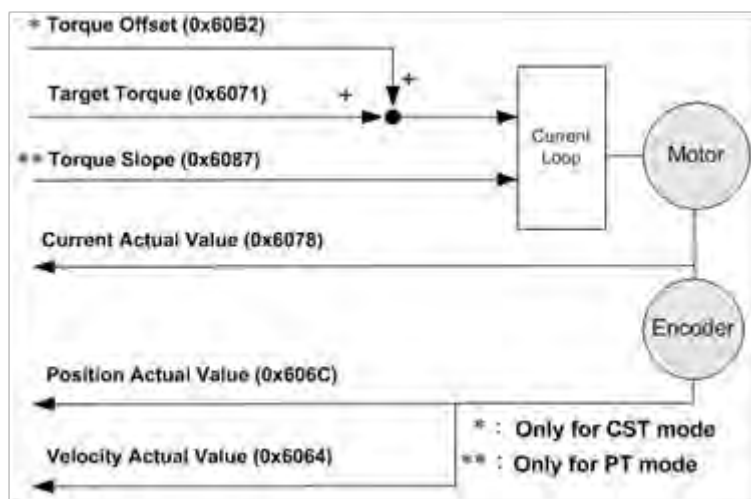

The objects used by the profile torque mode and cyclic synchronization torque mode are listed as follows:

- **Target torque (0x6071):** The input of target torque is based on the per millage form of motor continuous current transmitting to the drive. Range is 1000~1000 and the unit is 0.1% of motor continuous current. Default value is 0. It indicates that the pre-setting current command is 0% of motor continuous current.

Index	Sub-index	Name	Type	Access	Value	PDO mapping
0x6071	0x00	Current Command (Target Torque)	INT16	RW	-1000~1000	0

- **Torque slope (0x6087):** This is the slope of current command under the set up profile torque mode. The unit is 0.1%/sec variation of continuous current command and the default value is 1000.

Index	Sub-index	Name	Type	Access	Value	PDO mapping
0x6087	0x00	Current Slope	UINT32	RW	0~4294967295	0



## Drive User Guide

- Actual current value (0x6077): The actual current output to motor which is based on the permillage form of motor continuous current. The unit is 0.1%.

Index	Sub-index	Name	Type	Access	Value	PDO mapping
0x6078	0x00	Actual Current Value	UINT16	RO	- [0.1%]	0

- Motor rate current (0x6075): Indicate the continuous current of motor. The unit is ampere (A-amp).

Index	Sub-index	Name	Type	Access	Value	PDO mapping
0x6075	0x00	Motor Rated Current	REAL32	RO	- [A-amp]	X

- Torque Offset (0x60B2): In the cyclic synchronization torque mode, it is set to offset value and added into the torque reference command.

Index	Sub-index	Name	Type	Access	Value	PDO mapping
0x60B2	0x00	Torque Offset	INT16	RW	- [0.1%]	0

The steps used to operate the motor under the profile torque mode are listed as follows:

- Confirm the target velocity command 0x6071 has been mapping to RxPDO. The actual torque 0x6077, actual position 0x606C object or actual speed 0x6064 have been mapping into TxPDO. Please refer to Chapter 7, the setting method of PDO mapping.
- A. If the drive is operated under the profile torque mode, the content of 0x6060 shall be set to 4.  
B. If the drive is operated under the cyclic synchronization torque mode, the content of 0x6060 shall be set to 10.
- A. If the content of 0x6061 shows 4. It indicates that it has been switched to the profile torque mode.  
B. If the content of 0x6061object shows 10. It indicates that it has been switched to the cyclic synchronization torque mode.
- A. Under the profile torque mode, set up the torque slope (0x6087) first, then set up the target torque (0x6071). Allowing the drive receive the target torque and then output the current to the target torque value within the specific time in accordance with the set up slope.

Under the cyclic synchronization torque mode, set up the target torque (0x6071) directly and let the motor be operated.

## 9.4 Homing Mode

The figure shown below is the control schematic diagram of homing mode. The host selects the homing method and then sets up the homing speed, homing acceleration, and homing offset. By setting up ControlWord(0x6040), homing procedures are initiated.

## Drive User Guide

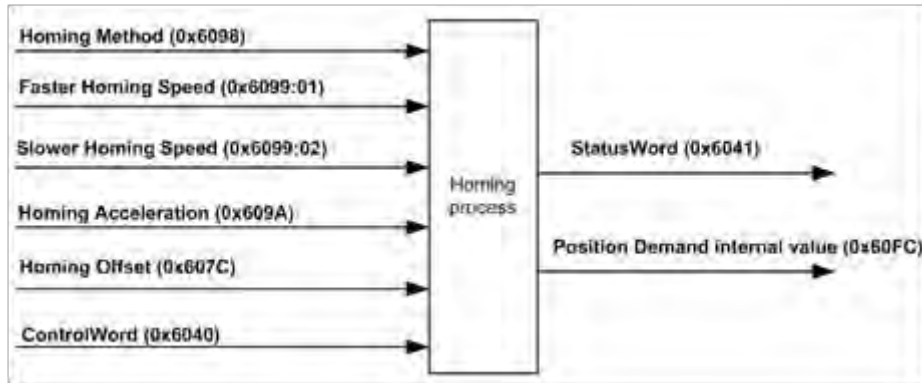

The following listed objects are special used under homing mode:

(1) Homing method (0x6098): Drive supports 8 kinds of CiA402 homing methods.

Index	Sub-index	Name	Type	Access	Value	PDO mapping
0x6098	0x00	Homing Method	UINT16	RW	0	X

(2) Faster homing speed (0x6099:01): Drive will use this speed to move motor to search the positive/negative limit or homing switch.

Index	Sub-index	Name	Type	Access	Value	PDO mapping
0x6099	0x01	Faster Homing Speed	UINT32	RW	—	X

(3) Slower homing speed (0x6099:02): Drive will use this speed to move motor to search the homing signal.

Index	Sub-index	Name	Type	Access	Value	PDO mapping
0x6099	0x02	Slower Homing Speed	UINT32	RW	—	X

(4) Homing Acceleration (0x609A)

Index	Sub-index	Name	Type	Access	Value	PDO mapping
0x609A	0x00	Homing Acceleration	UINT32	RW	—	X

(5) Homing Offset (0x607C): It is the offset between the coordinate origin and homing signal.

Index	Sub-index	Name	Type	Access	Value	PDO mapping
0x607C	0x00	Homing Offset	INT32	RW	—	X

The following list shows homing methods supported by drive (0x6098,Homing Method) :

Value	Description
0	No homing mode.

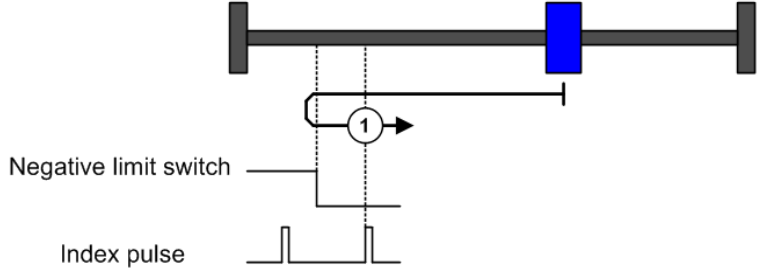
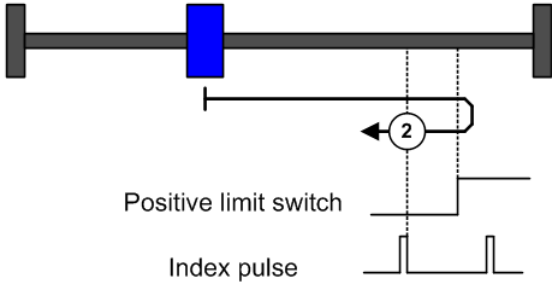
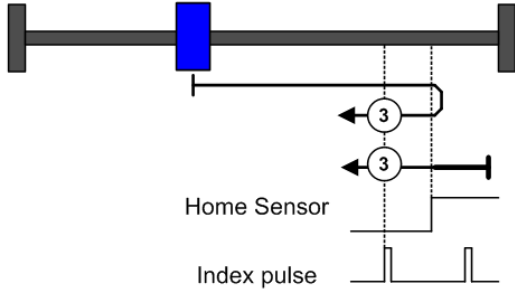
<p>1</p>	<p><b>Negative limit switch and index signal homing mode:</b></p> <p>In this mode, the motor will move to the negative direction until the negative limit switch is triggered. Then the motor will move to the positive direction. After the light of negative limit switch turns off, the location of the first triggered index signal is seen as homing position.</p> 
<p>2</p>	<p><b>Positive limit switch and index signal homing mode:</b></p> <p>In this mode, the motor will move to the positive direction until the positive limit switch is triggered. Then the motor will move to the negative direction. After the light of positive limit switch light turns off, the location of the first triggered index signal is seen as homing position.</p> 
<p>3</p>	<p><b>Positive-direction homing switch and index signal homing mode:</b></p> <p>In this mode, the motor will move to the positive direction until the homing switch is triggered. Then the motor will move to the negative direction. After the light of homing switch turns off, the location of the first triggered index signal is seen as homing position.</p> 

4 **Positive-direction homing switch and index signal homing mode:**

In this mode, the motor will move to the positive direction until the homing switch is triggered. Then the motor will continuously move to the positive direction. After the light of homing switch turns off, the location of the first triggered index signal is seen as homing position.

5 **Negative-direction homing switch and index signal homing mode:**

In this mode, the motor will move to the negative direction until the homing switch is triggered. Then the motor will move to the positive direction. After the light of homing switch turns off, the location of the first triggered index signal is seen as homing position.

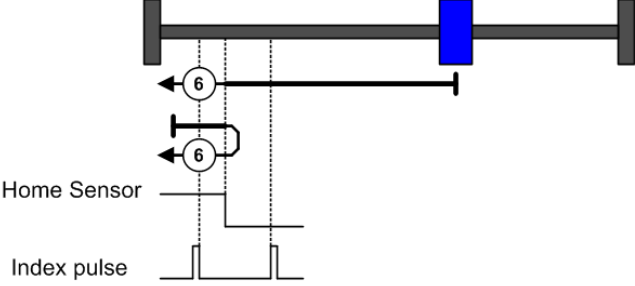
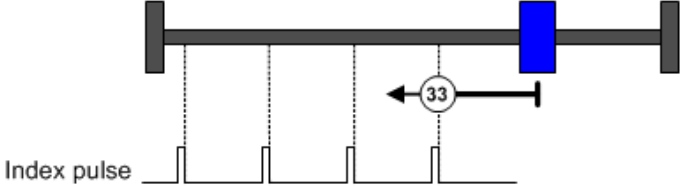
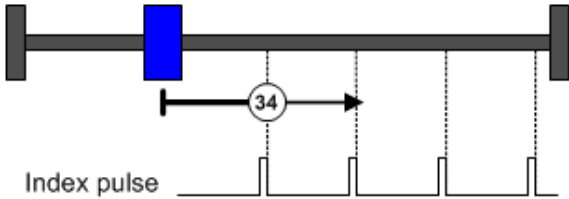
<p>6</p>	<p><b>Negative-direction homing switch and index signal homing mode:</b>                  In this mode, the motor will move to the negative direction until the homing switch is triggered. Then the motor will continuously move to the negative direction. After the light of homing switch turns off, the location of the first triggered index signal is seen as homing position.</p> 
<p>33</p>	<p><b>Searching homing signal in the negative direction mode:</b>                  In this mode, the motor will move to the negative direction to search the position of the first triggered index signal. This position is seen as homing position.</p> 
<p>34</p>	<p><b>Locate the homing signal mode toward to positive direction:</b>                  In this mode, the motor will move to the positive direction to search the position of the first triggered index signal. The position is seen as homing position.</p> 

The start, stop, and state report of homing are implemented separately through the content of ControlWord and StatusWord, shown as tables below:

## Drive User Guide

ControlWord (0x6040)		Description
Bit	Value	
4	0	Not start homing procedures.
	1	Start homing procedures.
8	0	Not stop homing procedures.
	1	Stop homing procedures.

StatusWord (0x6041)				Description
Bit15	Bit13	Bit12	Bit10	
Accuracy Compensation Initiated	Error	Search Homing	Reach Target	
×	0	0	0	Performing homing procedures.
×	0	0	1	Homing procedures interrupted or not initiated.
×	0	1	0	Index signal found but not at the target position.
×	0	1	1	Homing procedures completed.
1	0	1	1	Homing completed, the feedback position of motor cleared to zero, and accuracy compensation initiated.
×	1	0	1	Homing fail.

The steps of using homing mode to search homing are shown as follows:

- Set up the content of 0x6060 to 6 and operate the drive under homing mode.
- Set up the content of 0x6098 to the desired homing method.
- Set up the homing acceleration (0x609A), homing speed (0x6099:01, 0x6099:02), and homing offset (0x607C).
- Set up the Bit4 of ControlWord(0x6040) to 1 to start homing procedures.
- Wait the bit10 and bit12 of StatusWord been set to 1, i.e. homing is completed.
- Clear the Bit4 of ControlWor(0x6040) to 0.

### Initiate Accuracy Compensation:

When the host requires the drive to initiate the accuracy compensation mechanism after completing the homing, it can set up the object of EtherCAT input function (0x2020) to achieve this requirement. The steps are shown as follows:

- I. Use the human machine interface of HIWIN drive, called Lightning program. Fill the applicable content into compensation table at the Error Map page of application center window as shown in the figure below.

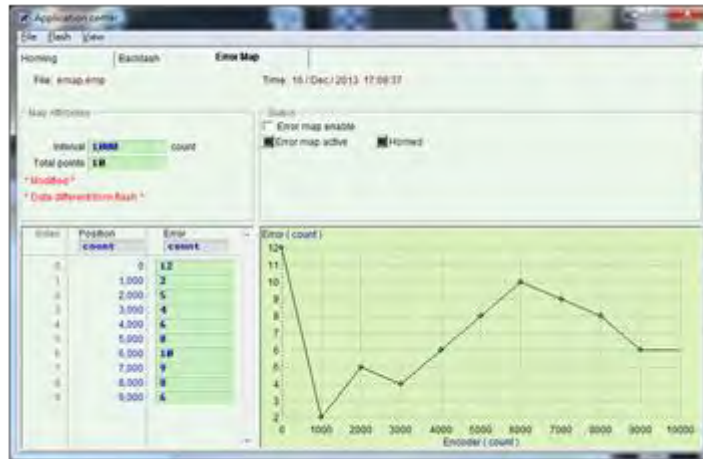

II. Save the accuracy compensation table into flash as shown in the figure below.

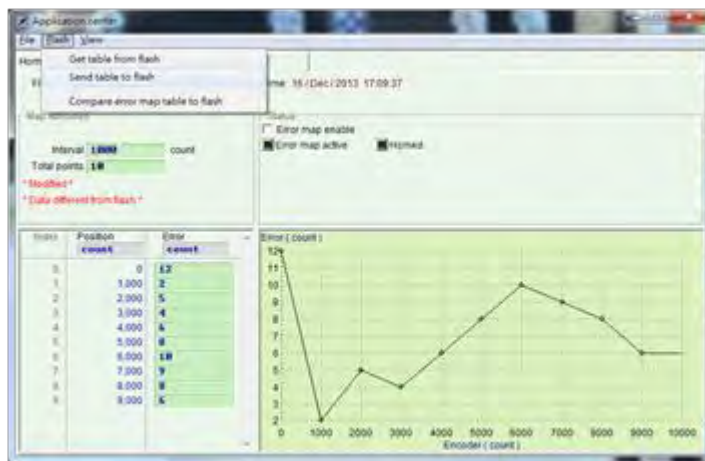

III. Enable the function of accuracy compensation as shown in the figure below.

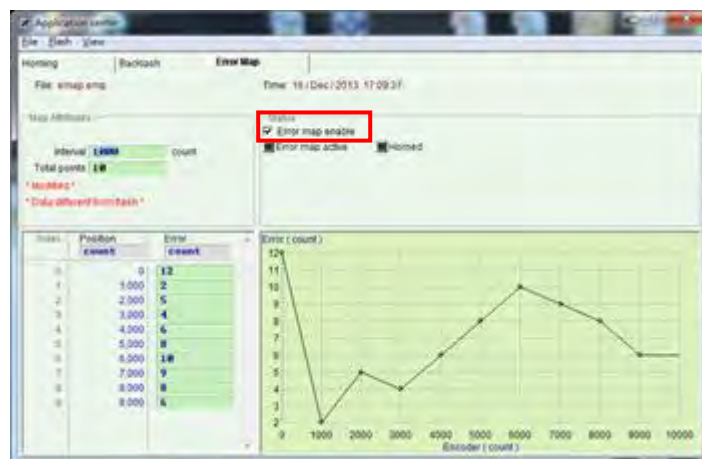

IV. Save the new parameter settings into the flash of drive as shown in the figure below.

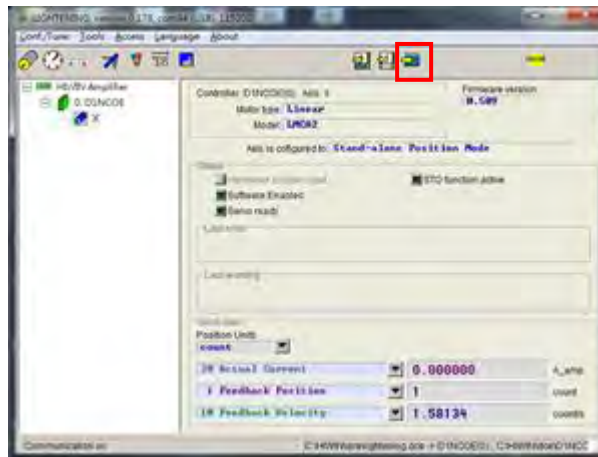

- V. The host uses the above homing steps to start homing procedures.
- VI. When the host reads the Bit10 and Bit12 of StatusWord(0x6041) being set to 1, this indicates that the homing of drive has been completed. The host sets up the Bit0 of EtherCAT input function object (0x2020) to 1, and thus informs drive to trigger the accuracy compensation function. If the Bit0 is set up to 0, the accuracy compensation function will not be enabled.
- VII. When the host reads the Bit10, Bit12 and Bit15 of StatusWord(0x6041) being set to 1, this indicates that the accuracy compensation function has been enabled and the feedback position of motor has been cleared to 0.
- VIII. Before the host switches the operational mode back to the position control mode (profile position mode or cyclic synchronization position mode), it shall re-assign the command position to be the feedback position of motor from drive. This can prevent from occurring mistake since the host detects a too large position error between the command position and the feedback position of motor after switching back to the position control mode.



# 10. Touch Probe Function

The feedback position can be latched with the encoder zero signal (Z-phase). There is only one touch probe function can be used in drive which named Touch Probe Function 1.

Touch Probe Function 1:

- Latch Control Object: 0x60B8 (Bit 0 to 7)
- Latch Status Object: 0x60B9(Bit 0 to 7)
- Latch Position is always stored to the Touch Probe Position Value (0x60BA)
- Trigger Signal: encoder zero signal (Z-phase)

Index	Sub-index	Name	Type	Access	Default Value	PDO mapping
0x60B8	0x00	Touch Probe Function	UINT16	RW	—	O
0x60B9	0x00	Touch Probe Status	INT32	RO	—	O
0x60BA	0x00	Touch Probe 1 Position Value	INT32	RO	—	O

Example of the handshaking procedure for the touch probe function

■ Single Trigger Mode (0x60B8 bit 1 =0)

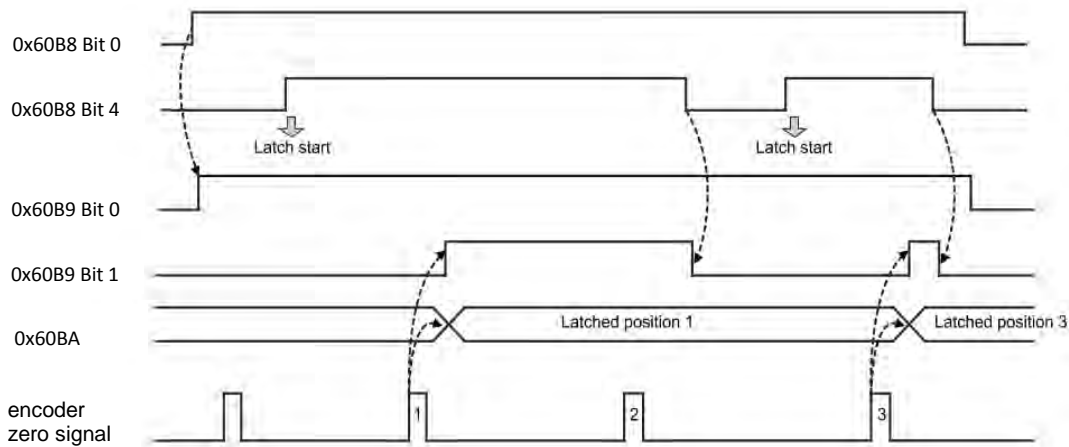

# Drive User Guide

## ■ Continuous Trigger Mode (0x60B8 bit 1 =1)

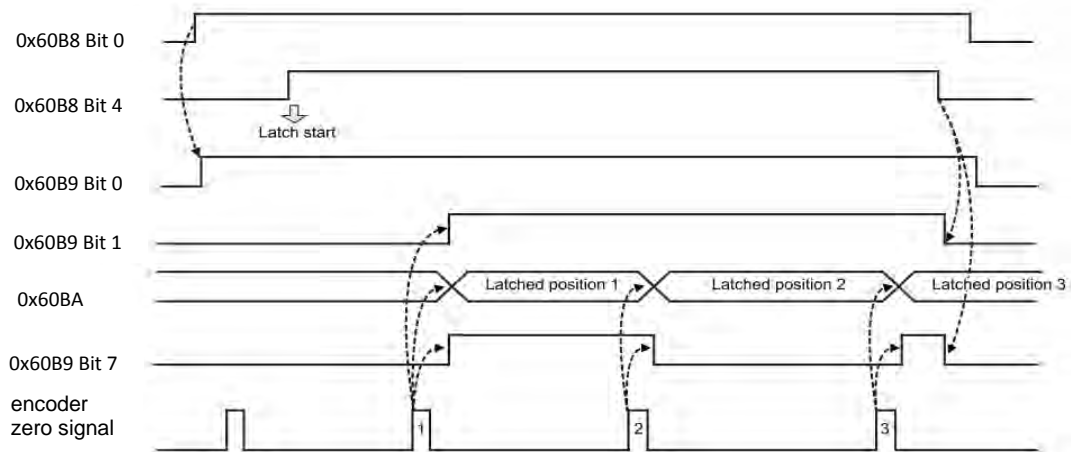

# A. How to use TwinCAT making connection with drive

Step 1.

Place ESI file such as D2COE.xml file of D2 EtherCAT drive in the folder of C:\TwinCAT\Io\EtherCAT.

Step 2.

Open TwinCAT System Manager as shown in the figure below.

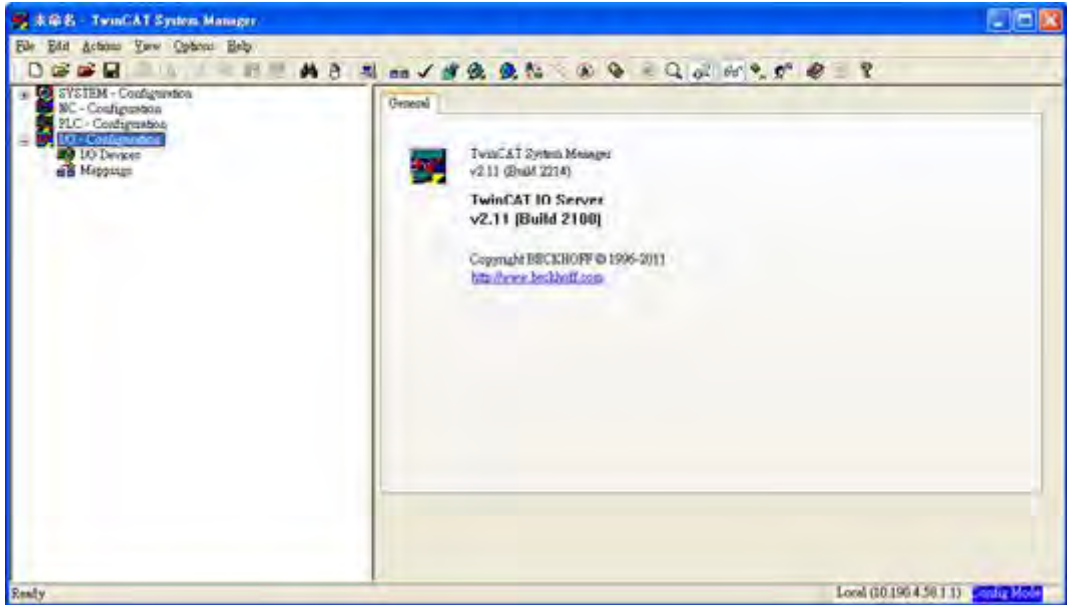

Step 3.

Right-click mouse on I/O Devices and select Scan Devices from the popout manu as shown in the figure below.

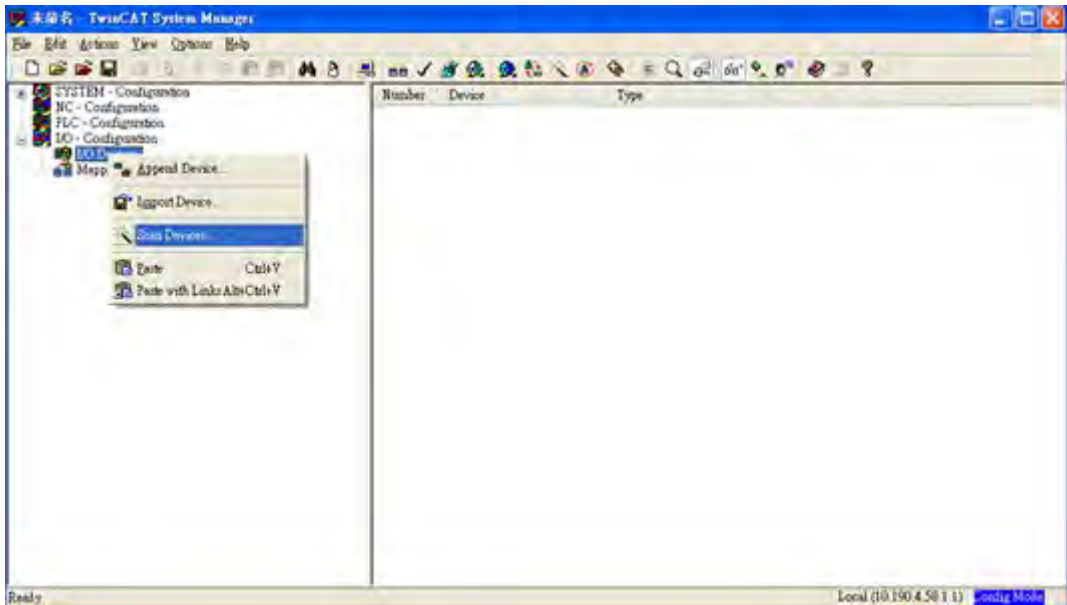

## Drive User Guide

### Step 4.

When popout the window of "HINT: Not all types of devices can be found automatically", please click OK as shown in the figure below.

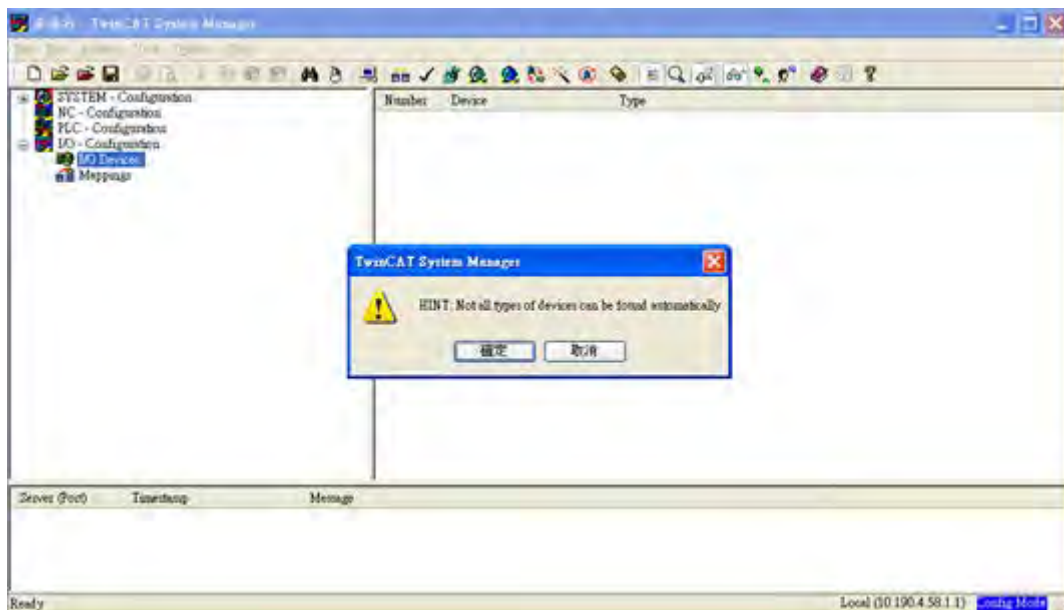

### Step 5.

Select the network card supporting EtherCAT and click OK as shown in the figure below.

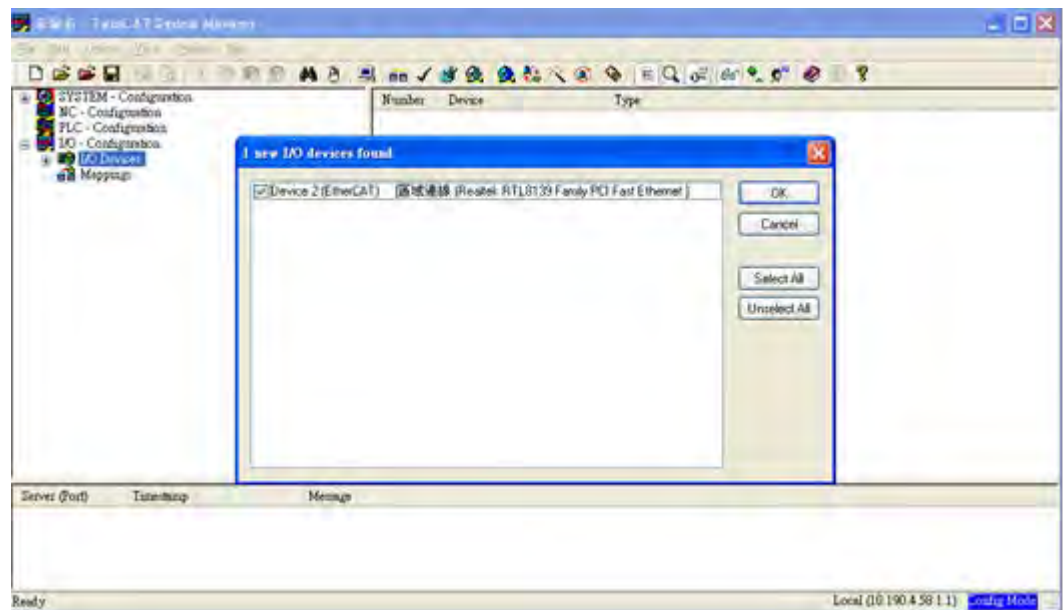

## Drive User Guide

### Step 6.

When popout the window of "Scan for boxes", please click YES as shown in the figure below.



### Step 7.

At this time, the operational interface of TwinCAT shown "D2 CoE Drivers".

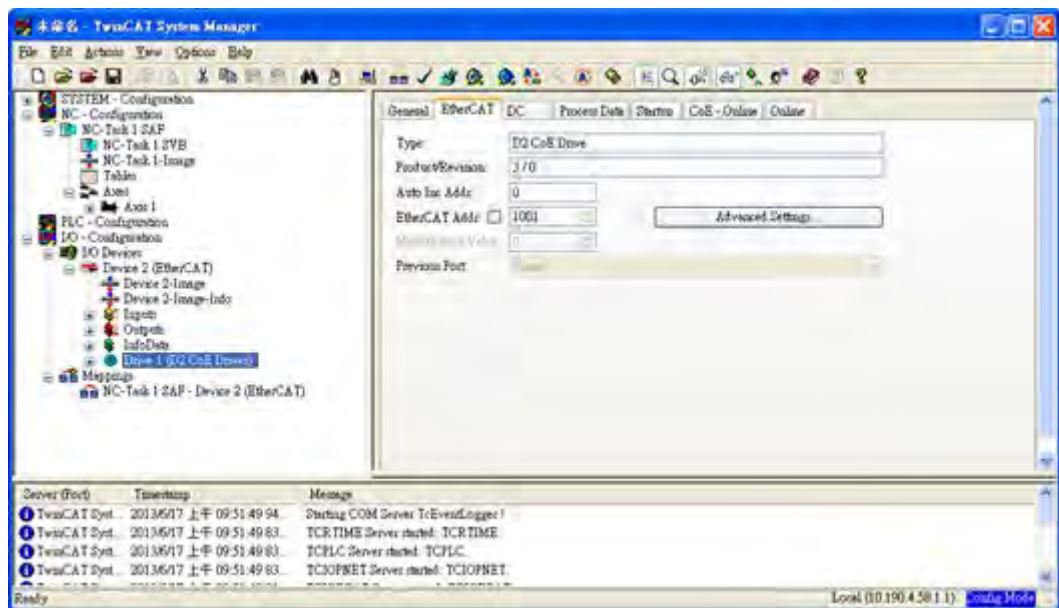

## B. How to use TwinCAT operating drive in position mode

Step 1.

Click Axis 1\_Enc under the tree diagram of Axis 1 and set up the Scaling Factor of Encoder in Parameter in the right side window. The unit of Scaling Factor is mm/INC.

Calculation example of AC servo: If the encoder of AC servo motor is 17 bits, screw pitch is 5mm. The calculation result of Scaling Factor is:  $5/131072 = 0.00003814697265625$ .

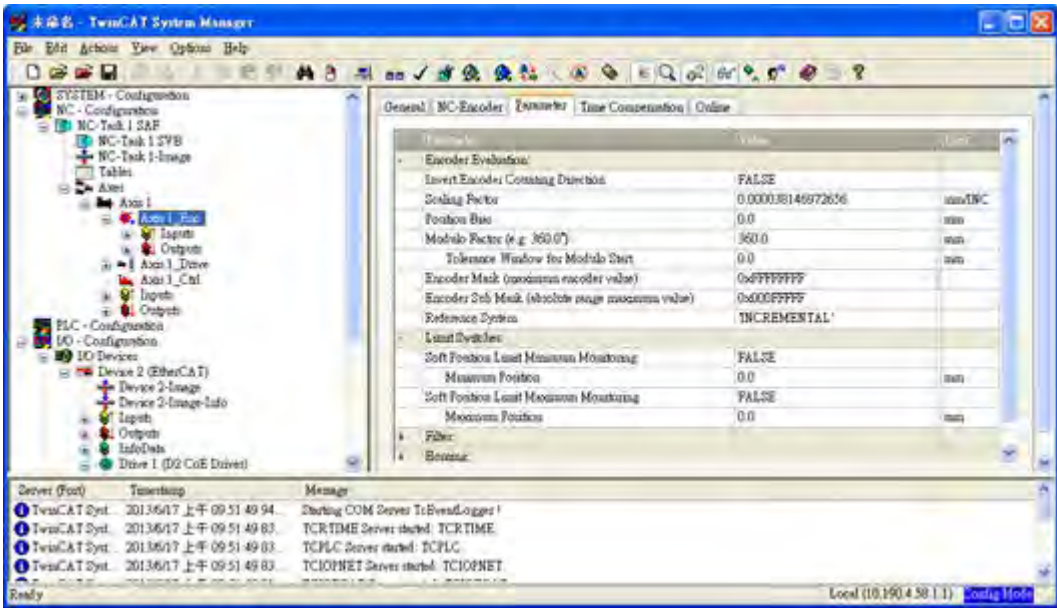

Step 2.

Click Axis 1 and set up the various protection value of position application monitor from the page of Monitoring in Parameter in the right side window. This setting shall be designed refer to the application of machine.

## Drive User Guide

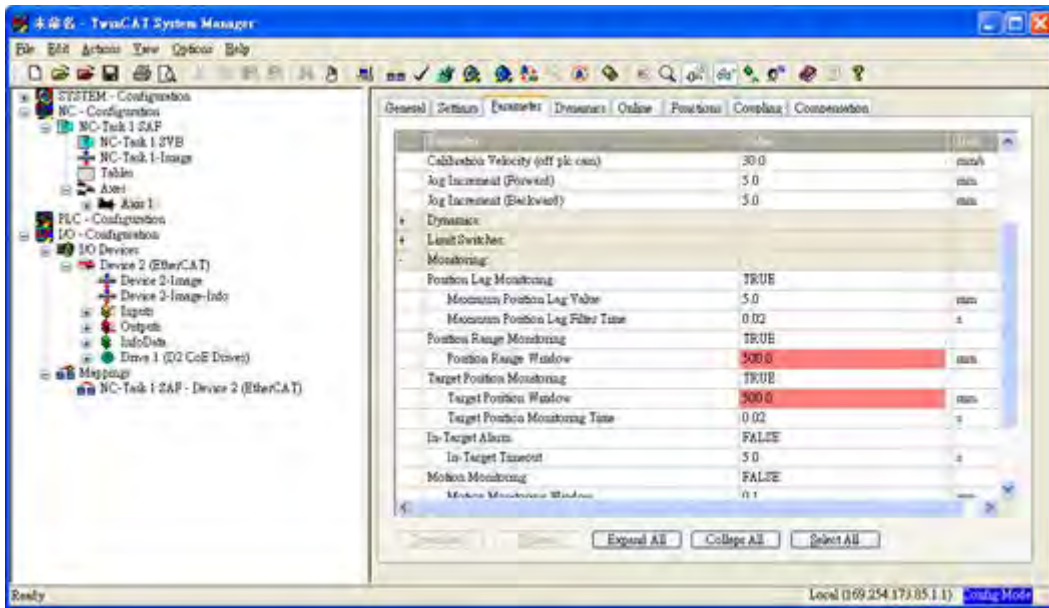

### Step 3.

On the DC page of Drive 1 (D2 CoE Drives), set up TwinCAT operating in DC- Synchorn synchronization mode as shown in the figure below. (Note: The default synchronization cycle time of TwinCAT is 2 ms)

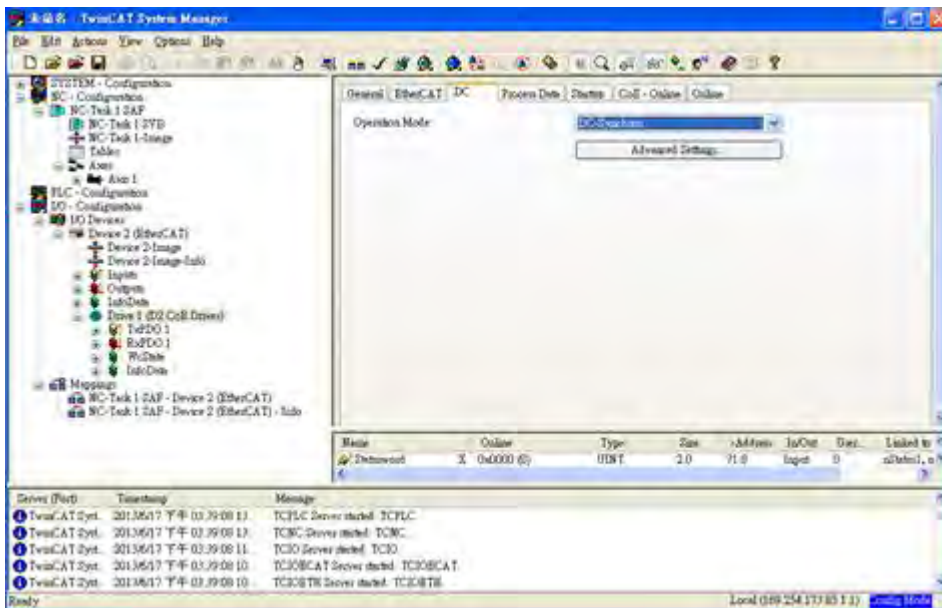

### Step 4.

Execute TwinCAT in Run Mode. Click in sequence "Generate mappings", "Check configuration", "Activate configuration" and "Set/Reset TwinCAT to Run Mode(Ctrl+F4)".

# Drive User Guide

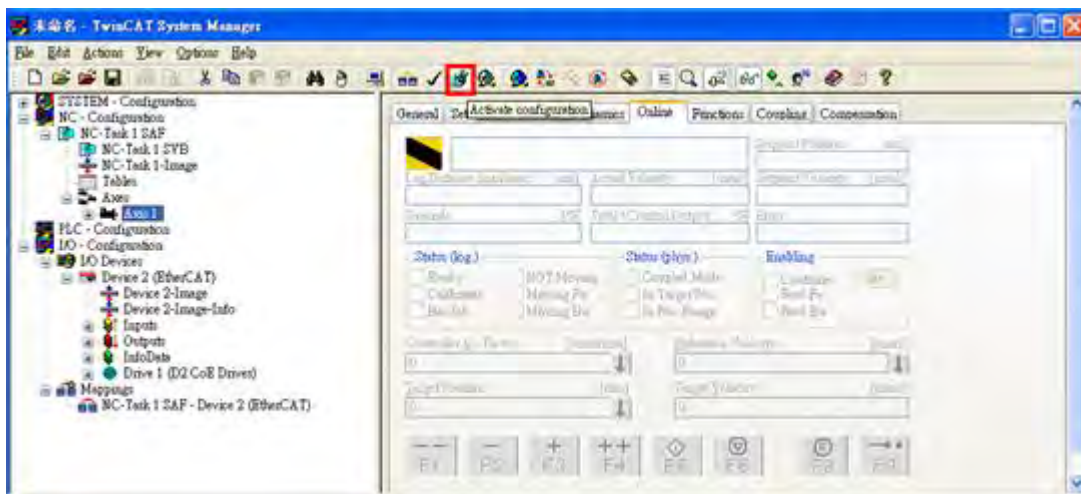
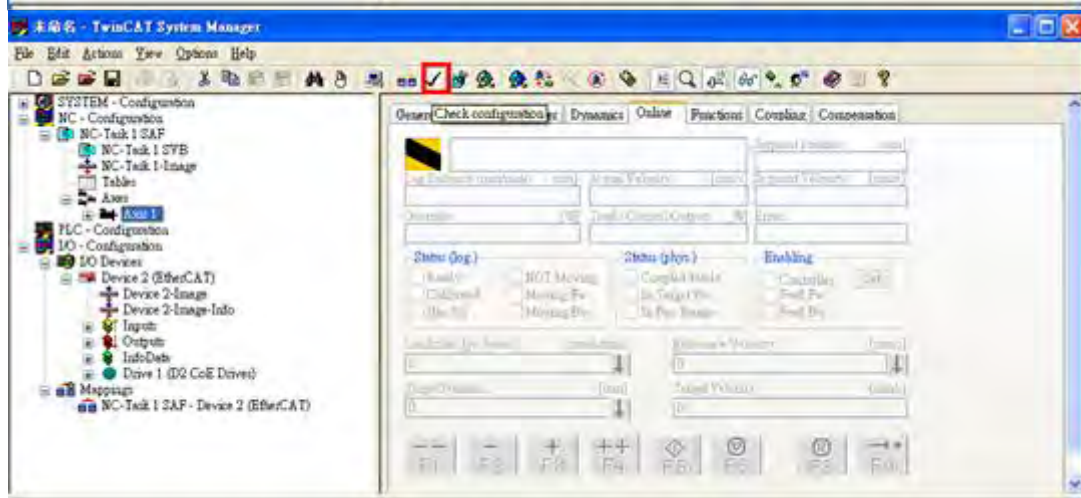
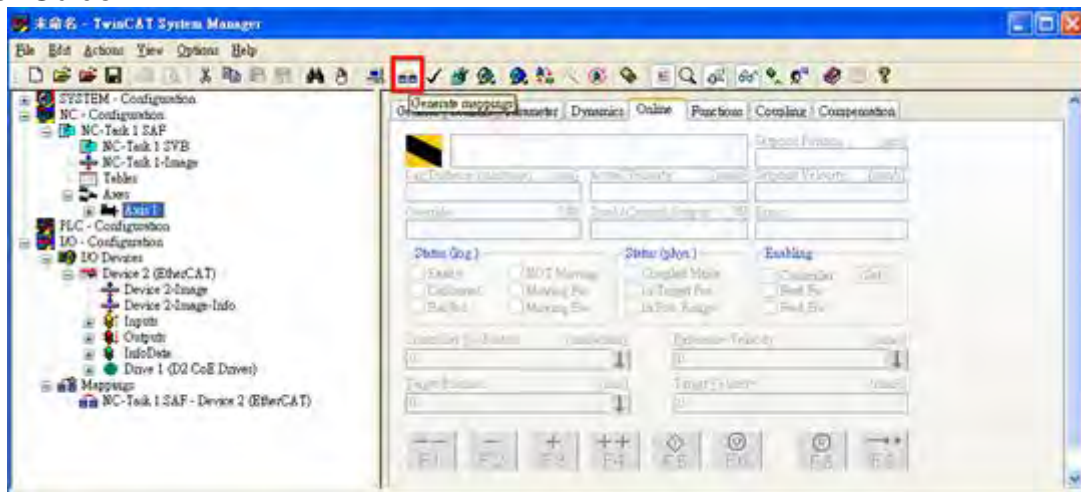



Drive User Guide

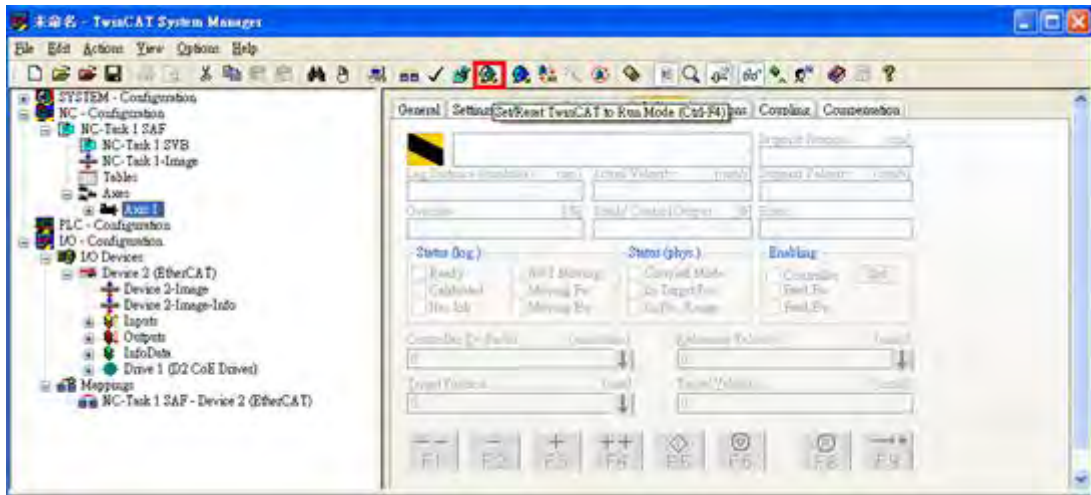

Step 5.

On the page of Drive 1 (D2 CoE Drives)->RxPDO 1 ->Mode of Operation->Online, click Force button and input value 8. Force to set up the operational mode to the Cyclic Position Mode.

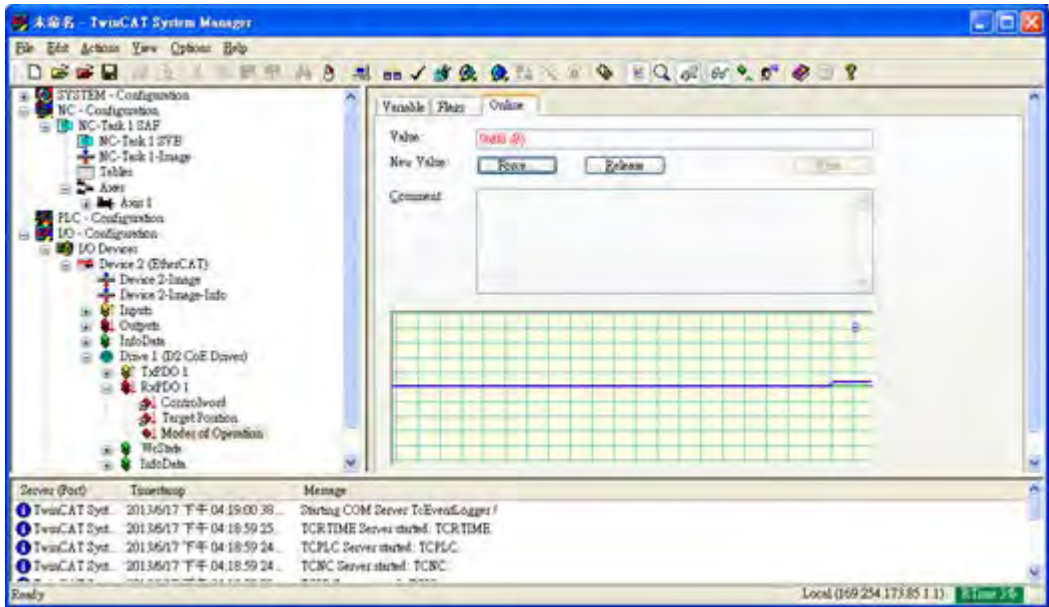

Step 6.

On the page of Drive 1->CoE Online, search 0x607D:01(Min Software Position Limit) and 02(Max Software Position Limit). Input applicable position limit value as shown in the figure below. (Note: The unit is count)

# Drive User Guide

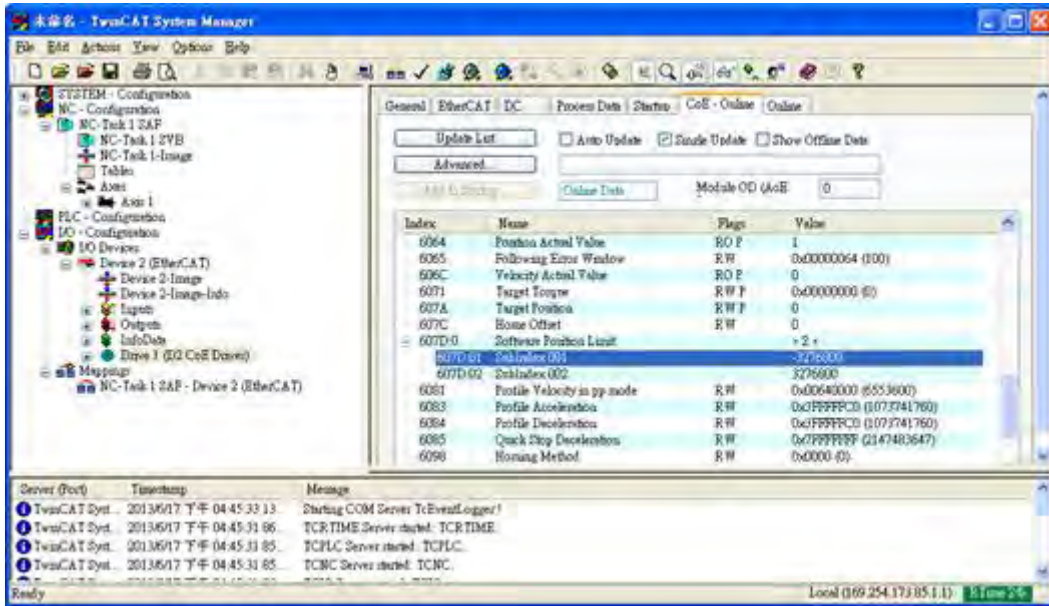

## Step 7.

At the right side of Online page of Axis 1, press Set button in Enabling block. Press All button at the right corner of popout window (Set Enabling) to magnetize motor.

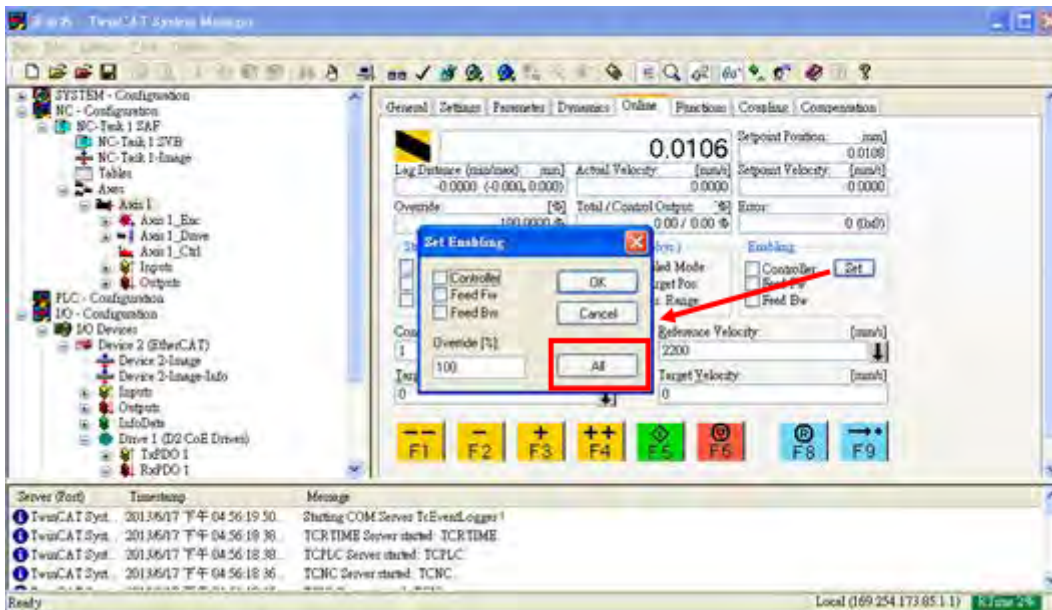

## Step 8.

On the page of Online, click the four buttons in the red box area or press F1~F4 on the keyboard to process the Jog movement of motor.

## Drive User Guide

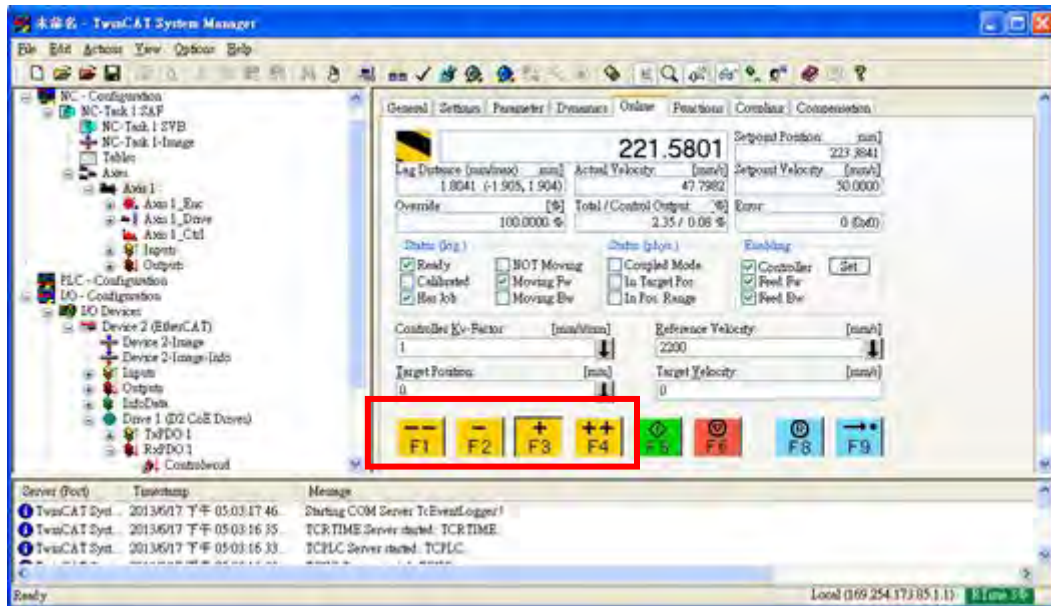

### Step 9.

At the right side of Online page of Axis 1, press Set button in Enabling block. Check cancel of Controller, Feed Fw and Feed Bw from the popout window and press OK button to de-magnetize motor.

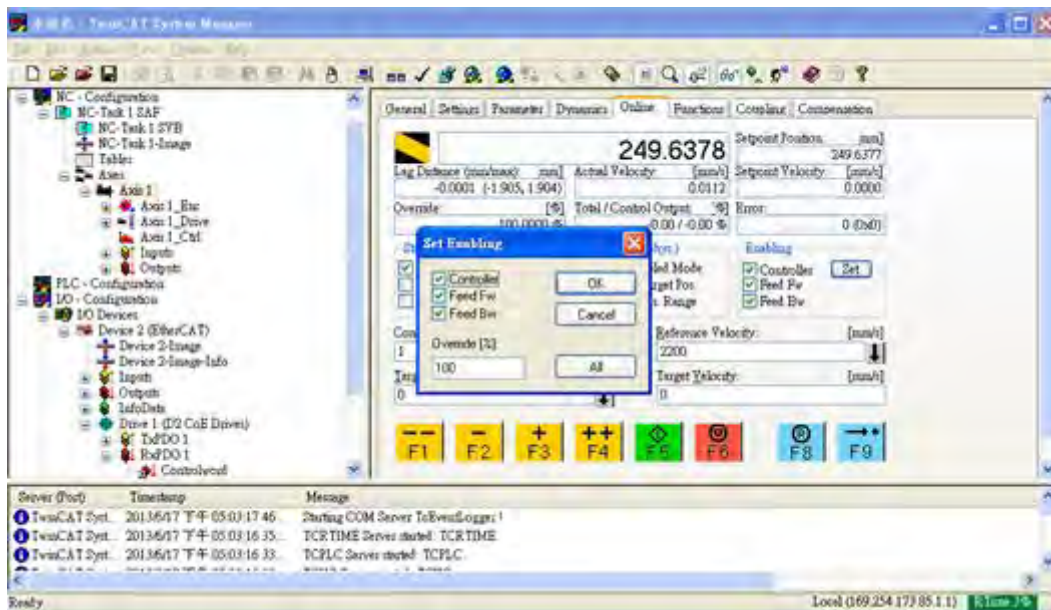

# C. How to use TwinCAT to process dynamic PDO

## Mapping

### Step 1.

On the page of Drive 1->Process Data, click 0x1A00(TxPDO) in PDO List. Then modify or add PDO Context(0x1A00) located below with the Mapping object to be add, delete or modify This text adds "Mode of Operation Display" object to TxPDO. Double Click on the blank object behind 0x606C(Velocity Actual Value). When Edit Pdo Entry window popout, click 0x6061 and then click OK as shown in the figure below.

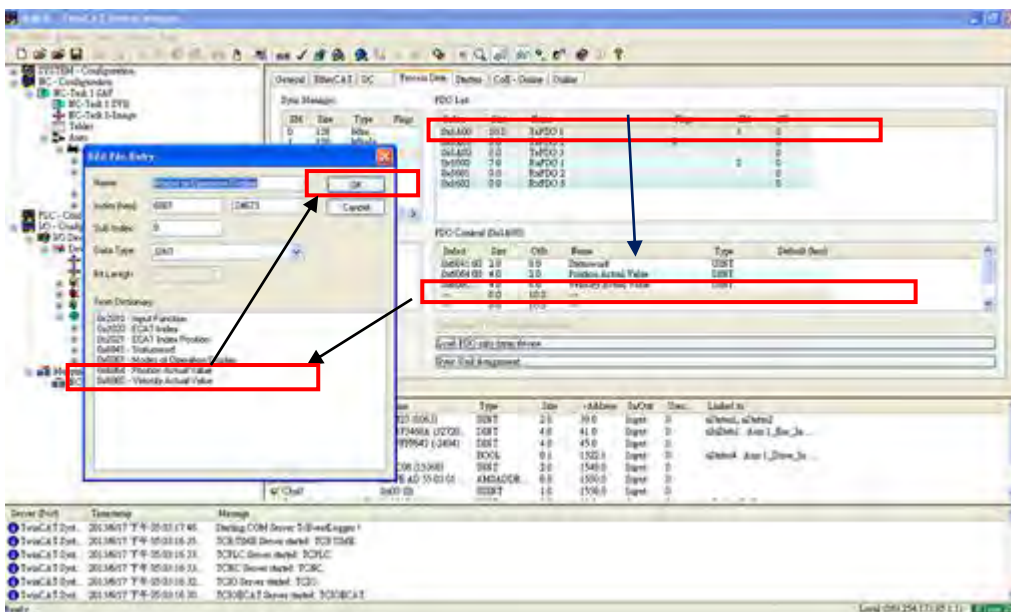

### Step 2.

Please repeatedly execute Step 4 of Note 2. Initiate TxPDO setting of Step 1.

### Step 3.

If the Mapping object of RxPDO requires to modify, please select 0x1600 to implement the modification. Then execute Step 2 to initiate the setting of RxPDO.

## D. How to setup the Operational Mode for EtherCAT

If Lightning connects to D1COE/D2COE/D1NCOE drive, then the options of Position Mode, Velocity Mode and Force/Torque Mode shown in the Mode page of Configuration center will be invalid and unable to click. Only the option of Stand-Alone Mode is default setting and valid. Besides, the option of EtherCAT Operation Mode will also be shown as shown in the figure below. Before setting up the motor, the option of EtherCAT Operation Mode is default setting and invalid; and will unable to click. Once the setting of motor is completed and re-open the Mode page of Configuration center, then this option will be valid and can be set up by the user. After the option of EtherCAT Operation Mode has been set up, then the controller of master station EtherCAT will be able to operate the drive normally.

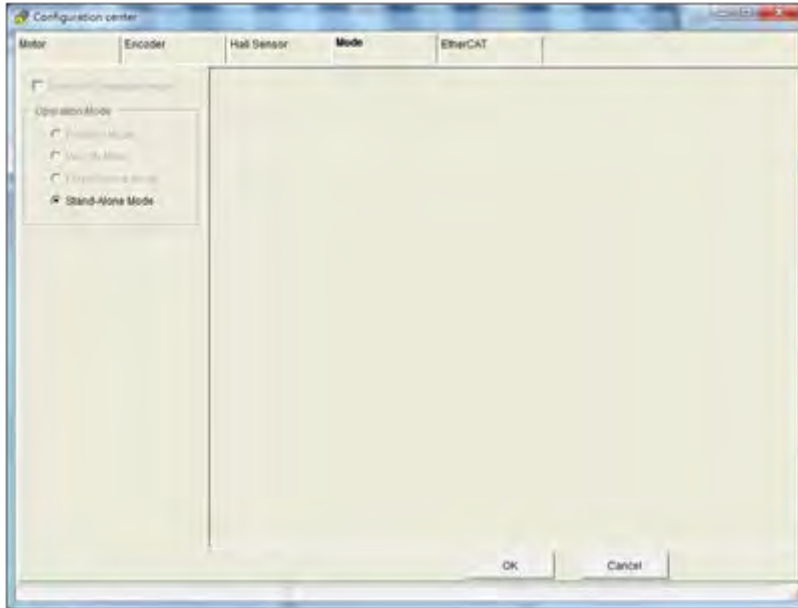

Before setting up the motor.



After completing the setting of motor.

## Drive User Guide

- When Lightening connects to EtherCAT drive and access in Performance center, the Home and Set button are deactivated as shown in the figure below because homing mode is already defined in CiA402 standard and the built-in homing procedures are not available to use.

